

Driadi

PORTE INTERNE

Indice

COLLEZIONE KUADRA <i>KUADRA COLLECTION</i> <i>COLLECTION KUADRA</i> <i>COLECCIÓN KUADRA</i>	19	SISTEMI DI APERTURA E ACCESSORI INCONTRI <i>OPENING SYSTEMS AND ACCESSORIES INCONTRI</i> <i>SYSTÈMES D'OUVERTURE ET ACCESSOIRES INCONTRI</i> <i>SISTEMAS DE APERTURA Y ACCESORIOS INCONTRI</i>	98
FINITURE KUADRA <i>KUADRA FINISHES</i> <i>FINITIONS KUADRA</i> <i>ACABADOS KUADRA</i>	32	VETRI INCONTRI <i>GLASS INCONTRI</i> <i>VERRE INCONTRI</i> <i>VIDRIO INCONTRI</i>	102
SISTEMI DI APERTURA E ACCESSORI KUADRA <i>OPENING SYSTEMS AND ACCESSORIES KUADRA</i> <i>SYSTÈMES D'OUVERTURE ET ACCESSOIRES KUADRA</i> <i>SISTEMAS DE APERTURA Y ACCESORIOS KUADRA</i>	34	COLLEZIONE LIGHT <i>LIGHT COLLECTION</i> <i>COLLECTION LIGHT</i> <i>COLECCIÓN LIGHT</i>	109
COLLEZIONE SOFT <i>SOFT COLLECTION</i> <i>COLLECTION SOFT</i> <i>COLECCIÓN SOFT</i>	39	FINITURE LIGHT <i>LIGHT FINISHES</i> <i>FINITIONS LIGHT</i> <i>ACABADOS LIGHT</i>	116
FINITURE SOFT <i>SOFT FINISHES</i> <i>FINITIONS SOFT</i> <i>ACABADOS SOFT</i>	52	ACCESSORI LIGHT <i>ACCESSORIES LIGHT</i> <i>ACCESSOIRES LIGHT</i> <i>ACCESORIOS LIGHT</i>	118
SISTEMI DI APERTURA E ACCESSORI SOFT <i>OPENING SYSTEMS AND ACCESSORIES SINERGIA</i> <i>SYSTÈMES D'OUVERTURE ET ACCESSOIRES SINERGIA</i> <i>SISTEMAS DE APERTURA Y ACCESORIOS SINERGIA</i>	54	VETRI LIGHT <i>GLASS INCONTRI</i> <i>VERRE INCONTRI</i> <i>VIDRIO INCONTRI</i>	121
VETRI KUADRA E SOFT <i>GLASS KUADRA END SOFT</i> <i>VERRE KUADRA ET SOFT</i> <i>VIDRIO KUADRA I SOFT</i>	58	COLLEZIONE METRICA <i>METRICA COLLECTION</i> <i>COLLECTION METRICA</i> <i>COLECCIÓN METRICA</i>	123
COLLEZIONE INCONTRI <i>INCONTRI COLLECTION</i> <i>COLLECTION INCONTRI</i> <i>COLECCIÓN INCONTRI</i>	61	FINITURE METRICA <i>METRICA FINISHES</i> <i>FINITIONS METRICA</i> <i>ACABADOS METRICA</i>	150
FINITURE INCONTRI <i>INCONTRI FINISHES</i> <i>FINITIONS INCONTRI</i> <i>ACABADOS INCONTRI</i>	96	SISTEMI DI APERTURA E ACCESSORI METRICA <i>OPENING SYSTEMS AND ACCESSORIES METRICA</i> <i>SYSTÈMES D'OUVERTURE ET ACCESSOIRES METRICA</i> <i>SISTEMAS DE APERTURA Y ACCESORIOS METRICA</i>	153

Indice

COLLEZIONE ARMONIA <i>ARMONIA COLLECTION</i> <i>COLLECTION ARMONIA</i> <i>COLECCIÓN ARMONIA</i>	157	FINITURE STILE <i>STILE FINISHES</i> <i>FINITIONS STILE</i> <i>ACABADOS STILE</i>	206
FINITURE ARMONIA <i>ARMONIA FINISHES</i> <i>FINITIONS ARMONIA</i> <i>ACABADOS ARMONIA</i>	172	SISTEMI DI APERTURA E ACCESSORI STILE <i>OPENING SYSTEMS AND ACCESSORIES STILE</i> <i>SYSTÈMES D'OUVERTURE ET ACCESSOIRES STILE</i> <i>SISTEMAS DE APERTURA Y ACCESORIOS STILE</i>	209
COPRIFILI E CAPITELLI ARMONIA <i>ARMONIA CAPITALS AND ARCHITRAVES</i> <i>CAPITALES ET ARCHITRAVES ARMONIA</i> <i>CAPITEL Y CHAMBRANAS ARMONIA</i>	174	VETRI METRICA, ARMONIA, STILE <i>GLASS METRICA, ARMONIA AND STILE</i> <i>VERRE METRICA, ARMONIA ET STILE</i> <i>VIDRIO METRICA, ARMONIA Y STILE</i>	212
ACCESSORI ARMONIA <i>ACCESSORIES SINERGIA</i> <i>ACCESSOIRES SINERGIA</i> <i>ACCESORIOS SINERGIA</i>	175	SISTEMI DI APERTURA DRIADI <i>DRIADI OPENING SYSTEMS</i> <i>SYSTÈMES D'OUVERTURE DRIADI</i> <i>SISTEMAS DE APERTURA DRIADI</i>	217
COLLEZIONE ESSENZIA <i>ESSENZIA COLLECTION</i> <i>COLLECTION ESSENZIA</i> <i>COLECCIÓN ESSENZIA</i>	177	SCORREVOLE INTERNO MURO <i>INSIDE WALL SLIDING</i> <i>PORTE A GALANDAGE</i> <i>CORREDERA INTERIOR PARED</i>	219
FINITURE ESSENZIA <i>ESSENZIA FINISHES</i> <i>FINITIONS ESSENZIA</i> <i>ACABADOS ESSENZIA</i>	186	SCORREVOLE ESSENTIAL <i>ESSENTIAL SLIDING</i> <i>PORTE COULISSANTE ESSENTIAL</i> <i>CORREDERA ESSENTIAL</i>	220
SISTEMI DI APERTURA E ACCESSORI ESSENZIA <i>OPENING SYSTEMS AND ACCESSORIES ESSENZIA</i> <i>SYSTÈMES D'OUVERTURE ET ACCESSOIRES ESSENZIA</i> <i>SISTEMAS DE APERTURA Y ACCESORIOS ESSENZIA</i>	188	SCORREVOLE KATANA <i>KATANA SLIDING</i> <i>PORTE COULISSANTE KATANA</i> <i>CORREDERA KATANA</i>	223
VETRI ESSENZIA <i>GLASS ESSENZIA</i> <i>VERRE ESSENZIA</i> <i>VIDRIO ESSENZIA</i>	192	SCORREVOLE INKASSO <i>INKASSO SLIDING</i> <i>PORTE COULISSANTE INKASSO</i> <i>CORREDERA INKASSO</i>	225
COLLEZIONE STILE <i>STILE COLLECTION</i> <i>COLLECTION STILE</i> <i>COLECCIÓN STILE</i>	195	SCORREVOLE GLOBAL <i>GLOBAL SLIDING</i> <i>PORTE COULISSANTE GLOBAL</i> <i>CORREDERA GLOBAL</i>	227

Indice

SCORREVOLE MAGICUS <i>MAGICUS SLIDING</i> <i>PORTE COULISSANTE MAGICUS</i> <i>CORREDERA MAGICUS</i>	229	SCORREVOLE INKASSO PER ANTE IN VETRO <i>INKASSO SLIDING FOR GLASS DOORS</i> <i>PORTE COULISSANTE INKASSO POUR PORTES EN VERRE</i> <i>CORREDERA INKASSO PARA PANELES DE VIDRIO</i>	247
SCORREVOLE PRATICO <i>PRATICO SLIDING</i> <i>PORTE COULISSANTE PRATICO</i> <i>CORREDERA PRATICO</i>	231	MANIGLIE E MANIGLIONI <i>HANDLES AND PULLS</i> <i>POIGNÉES ET BARRE DE TIRAGE</i> <i>MANIJAS Y MANIJONES</i>	248
SCORREVOLE INCONTRA <i>INCONTRA SLIDING</i> <i>PORTE COULISSANTE INCONTRA</i> <i>CORREDERA INCONTRA</i>	233	FINITURE FERRAMENTA <i>DRIADI HARDWARE FITTINGS</i> <i>QUINCAILLERIE DRIADI</i> <i>ACABADOS DE HARDWARE DRIADI</i>	256
SCORREVOLE GRANLUCE <i>GRANLUCE SLIDING</i> <i>PORTE COULISSANTE GRANLUCE</i> <i>CORREDERA GRANLUCE</i>	235	PARTICOLARI TECNICI <i>TECHNICAL SHEET</i> <i>CARACTÉRISTIQUES TECHNIQUES</i>	258
SCORREVOLE CON MANTOVANA <i>SLIDING WITH PELMET</i> <i>PORTE COULISSANTE AVEC CANTONNIÈRE</i> <i>CORREDERA CON PELETS</i>	237		
PIEGHEVOLE A LIBRO <i>FOLDING DOOR</i> <i>PORTE PLIANTE</i> <i>PLEGABLE DE LIBRO</i>	239		
PIEGHEVOLE ASIMMETRICA <i>ASYMMETRICAL FOLDING DOOR</i> <i>PORTE PLIANTE ASYMETRIQUE</i> <i>PLEGABLE ASIMÉTRICA</i>	241		
SCORREVOLE MAGICUS PER ANTE IN VETRO <i>MAGICUS SLIDING FOR GLASS DOORS</i> <i>PORTE COULISSANTE MAGICUS POUR PORTES EN VERRE</i> <i>CORREDERA MAGICUS PARA PANELES DE VIDRIO</i>	243		
SCORREVOLE ODACHI PER ANTE IN VETRO <i>ODACHI SLIDING FOR GLASS DOORS</i> <i>PORTE COULISSANTE ODACHI POUR PORTES EN VERRE</i> <i>CORREDERA ODACHI PARA PANELES DE VIDRIO</i>	245		

Driadi

TRADIZIONE MADE IN ITALY

PRECISIONE STRUTTURALE, SCELTA DEI MATERIALI, CURA DEI DETTAGLI, LINEE DECISE ED ELEGANTI SONO I CAPISALDI DI UN VENTAGLIO DI NUOVE POSSIBILITÀ. È L'ESPRESSIONE DI UNA TRADIZIONE CHE SI MANTIENE NEL TEMPO, QUELLA DI CREARE E REALIZZARE PORTE COMPLETAMENTE MADE IN ITALY, ATTENTI AL DESIGN, ALL'ESTETICA E ALLA QUALITÀ.

TRADITION MADE IN ITALY

Structural precision, choice of materials, attention to details, decisive and elegant lines are the cornerstones of a range of new possibilities. It is the expression of a tradition that has been maintained over time, which of creating doors entirely made in Italy, attentive to design, aesthetics and quality.

TRADITION FABRIQUÉ EN ITALIE

Précision structurelle, choix des matériaux, souci des détails, lignes éloquentes et élégantes, sont les points fondamentaux d'une gamme de nouvelles possibilités. C'est l'expression d'une tradition qui s'est maintenue au fil du temps: celle de créer des portes entièrement fabriquées en Italie. Nous portons une attention toute particulière au design, à l'esthétique et à la qualité.

TRADICIÓN MADE IN ITALY

La exactitud estructural, la elección de los materiales, la atención al detalle, las líneas firmes y elegantes son los pilares de una gama de nuevas posibilidades. Es la expresión de una tradición de puertas completamente hechas en Italia, desde la creación hasta la fabricación, con atención al diseño, a la estética y a la calidad.

CLASSICA BELLEZZA

NELLA MITOLOGIA GRECA, LE DRIADI ERANO NINFEE CHE VIVEVANO NEL BOSCO: AFFASCINANTI E SOLARI, SI MUOVEVANO LIBERAMENTE E DANZAVANO AGGRAZIATE. ANCHE QUESTA È, IN FONDO, LA BELLEZZA CLASSICA, CHE SEMPRE SI RINNOVA E SI ADATTA AI TEMPI. COSÌ FORME GEOMETRICHE SI INCONTRANO E SI INCASTRANO, SPIGOLI SI SMUSSANO E SI ARROTONDANO, NUOVI ANGOLI GIOCANO TRA DI LORO. QUESTO È IL DINAMISMO, LA LEGGEREZZA E LA RAFFINATA SEMPLICITÀ.

CLASSICAL BEAUTY

In greek mythology, dryads were nymphs that lived in woods: beautiful and bright, they moved freely through nature and danced gently. An image meeting the idea of classical beauty, that always renews itself and aligns with times. In a similar way, geometric shapes meet and match, edges smooth down and round, new perspectives play with each other. This is what we call dynamism, lightness and simplicity with charm.

BEAUTÉ CLASSIQUE

Dans la mythologie grecque, les Dryades étaient des nymphes qui vivaient dans les bois. Fascinantes et solaires, elles se déménage librement et elles dansent avec élégance. Cela aussi est, après tout, la beauté classique, toujours renouvelée et adaptée aux époques. Ainsi des formes géométriques se rencontrent et s'emboitent. Les bords sont émoussés et arrondis ; de nouveaux coins jouent entre eux. C'est le dynamisme, la légèreté et la simplicité raffinée.

BELLEZA CLÁSICA

En la mitología griega, las driades eran las ninfas de los bosques: fascinantes y encantadoras, se movían libremente y bailaban del modo más armonioso. una imagen de la belleza en su forma clásica que siempre se renueva y se adapta a los tiempos. Así, las formas geométricas se juntan y encajan, los bordes se confunden, las esquinas se redondean. Todo esto es dinamismo, liviandad y refinada sencillez.



SISTEMA B-SYSTEM

*B-SYSTEM system
Système B-SYSTEM
Sistema B-SYSTEM*

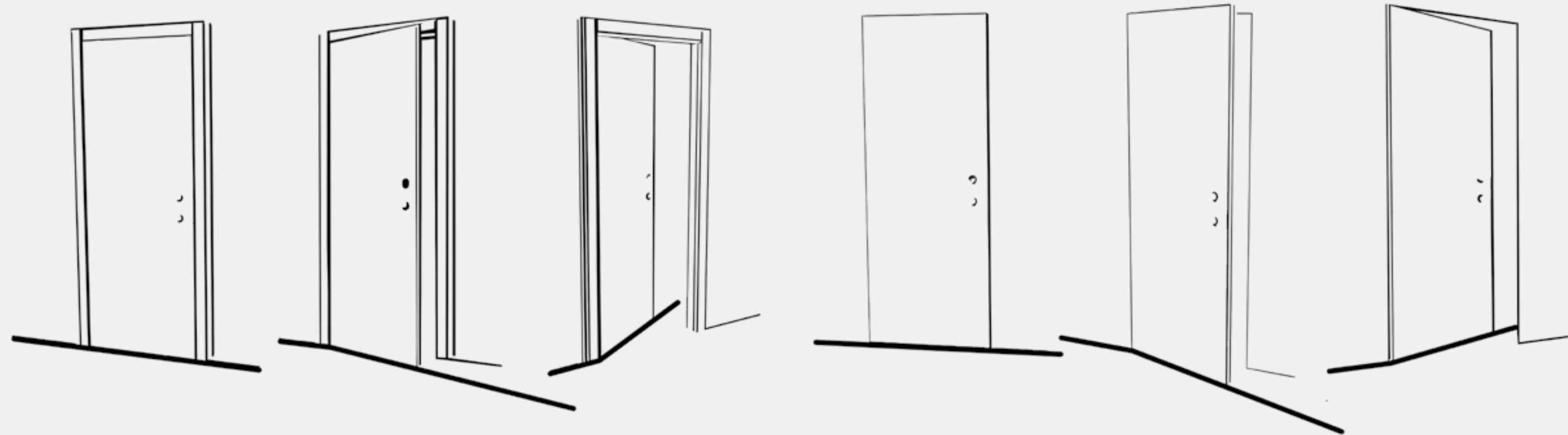

APERTURA COMPLANARE A TIRARE,
A SPINGERE E CLASSICA.
TUTTE LE SOLUZIONI IN UN UNICO SISTEMA.
L'UNIONE DEI TELAI B-ZERO, B-UNO,
B-DUE RENDE POSSIBILE TUTTO QUESTO,
GRAZIE ANCHE ALLA TOTALE COMPATIBILITÀ
CON IL SISTEMA KO-ZERO.
L'INTERCAMBIABILITÀ È IL PUNTO DI FORZA
DI QUESTA COLLEZIONE.

*Coplanar opening to pull, to push and classic. All solutions in one system.
The union of the B-ZERO, B-UNO and B-DUE frames makes all this possible,
thanks also to the total compatibility with the KO-ZERO system.
Interchangeability is the highlight of this collection.*

*Ouverture coplanaire pour tirer, pousser et classique.
Toutes les solutions réunies en un seul système.
L'union des cadres B-ZERO, B-UNO et B-DUE rend tout cela possible,
grâce également à la compatibilité parfaite avec le système KO-ZERO.
L'interchangeabilité est le point fort de cette collection.*

*Apertura a tirar, empujar y clásica. Todas las soluciones en un único sistema.
La unión de los marcos B-ZERO, B-UNO, B-DUE permite todo esto, gracias también a la plena
compatibilidad con el sistema KO-ZERO.
La fuerza de esta colección es la intercambiabilidad.*

Flessibilità

Flexibility

Flexibilité

Flexibilidad

FLESSIBILITÀ TOTALE È LA PAROLA D'ORDINE DI DRIADI. GRAZIE AL B-SYSTEM IN ABBINAMENTO AL KO-ZERO, QUESTA COLLEZIONE SI PONE AI VERTICI DEL MERCATO DI RIFERIMENTO QUANTO A FLESSIBILITÀ E GAMMA. TUTTE LE ESIGENZE TROVANO RISPOSTA IN DRIADI.

Total flexibility is the keyword of DRIADI, thanks to the B-SYSTEM combined with KO-ZERO, this collection is at the top of the reference market in terms of flexibility and product line. All needs are met in DRIADI.

La flexibilité totale est le maître-mot d'DRIADI, grâce au B-SYSTEM associé au KO-ZERO. Cette collection est au sommet du marché de référence en termes de flexibilité et de gamme. Apporte une solution à tous vos besoins DRIADI.

La flexibilidad total es la característica más importante de DRIADI. Gracias al B-SYSTEM en combinación con el KO-ZERO, esta colección se destaca en el mercado de referencia en cuanto a flexibilidad y gama. Todas las necesidades encuentran respuestas en DRIADI.

Allineamento coprifili

Alignment of architraves

Alignement des architraves

Alineación de chambranas

SISTEMA SCORREVOLE INTERNO MURO	SISTEMA B-ZERO Spingere	SISTEMA B-UNO Spingere	SISTEMA B-DUE Tirare	SISTEMA KO-ZERO
System inside wall sliding Système porte a galandage Sistema corredera interior pared	System B-ZERO push Système B-ZERO pousser Sistema B-ZERO a empujar	System B-UNO push Système B-UNO pousser Sistema B-UNO a empujar	System B-DUE pull Système B-DUE tirer Sistema B-DUE a tirar	System KO-ZERO Système KO-ZERO Sistema KO-ZERO

NEWS

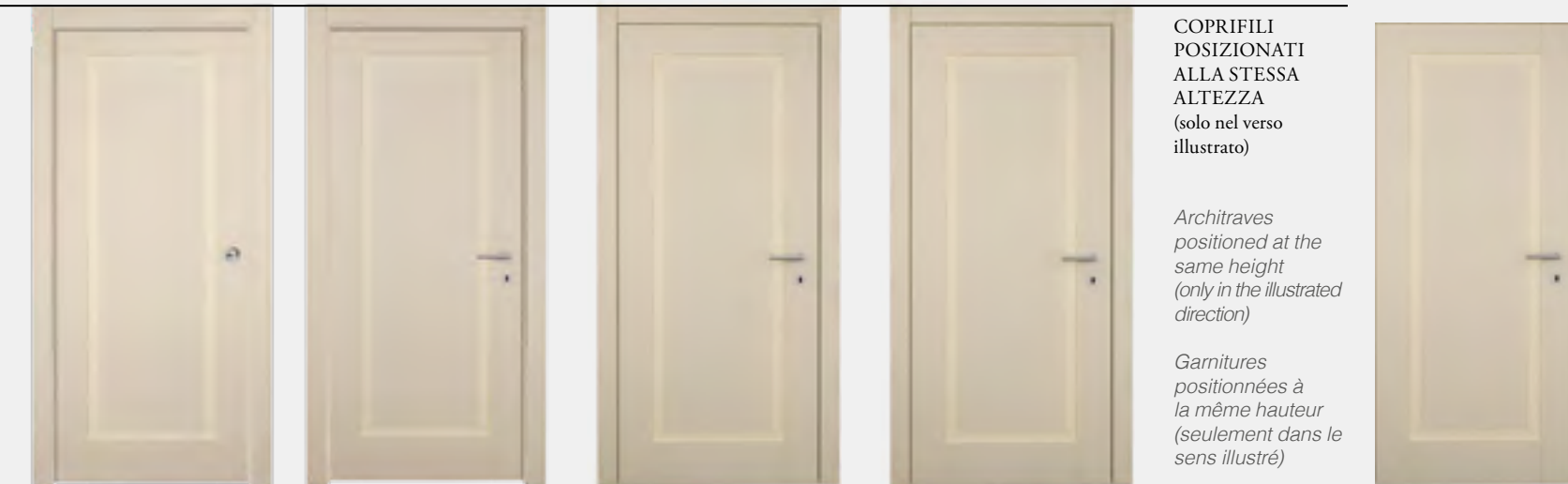

**COPRIFILI
POSIZIONATI
ALLA STESSA
ALTEZZA**
(solo nel verso
illustrato)

*Architraves
positioned at the
same height
(only in the illustrated
direction)*

*Garnitures
positionnées à
la même hauteur
(seulement dans le
sens illustré)*

*Chambranas
puestas a la misma
altura (solo en la
dirección ilustrada)*



**L'ALLINEAMENTO
È CONSENTITO
SOLO CON
L'UTILIZZO DEL
COPRIFILO Q60**

*Alignment is
allowed only with
the use of the Q60
architrave*

*L'alignement
est autorisé
uniquement avec
l'utilisation de Q60*

*La alineación
solo se permite
con el uso de la
chambrana Q60*

BELLA DA TOCCARE

Laccatura effetto Velluto

PER LA COLLEZIONE DRIADI ABBIAMO RISERVATO UNA LACCATURA SOFT TOUCH EFFETTO VELLUTO DISPONIBILE SU RICHIESTA. L'EFFETTO ALLA VISTA È DI UNA NATURALE OPACITÀ, MENTRE AL TATTO DONA UNA PIACEVOLE SENSAZIONE DI UNA SUPERFICIE A GRANA FINISSIMA, VELLUTATA E SOFFICE COME UNA PIUMA, CHE NON LASCIA IMPRONTE E CON UNA RESISTENZA AI GRAFFI SUPERIORE ALLA MEDIA. QUESTA FINITURA È OTTENUTA ATTRAVERSO UN ESCLUSIVO PROCESSO ARTIGIANALE. DOPO IL CLASSICO PROCESSO DI LACCATURA, INFATTI, VIENE APPLICATA UNA SPECIALE VERNICE CON ZERO GLOSS CHE DONA L'ASPETTO OPACO. INFINE, IL TUTTO È SOTTOPOSTO AD UN PROCESSO DI ESSICCAZIONE.

BEAUTIFUL TO TOUCH - Velluto effect lacquering

For the Driadi collection we have reserved a VELLUTO effect soft touch lacquer available on request. The effect at the sight is of a natural opacity, while to the touch it gives a pleasant sensation of a very fine, velvety and soft as a feather, which leaves no marks and with a scratch resistance above the average. This finish is obtained through an exclusive craft process. After the classic lacquering process, in fact, a special paint with zero gloss is applied which gives the opaque appearance. Finally, everything is subjected to a drying process.

BELLE AU TOUCHER - Laquage effet velluto

Pour la collection "Driadi" nous avons réservé une laque douce au toucher effet VELLUTO disponible sur demande. L'effet à la vue est d'une opacité naturelle, tandis qu'au toucher il procure une agréable sensation de surface à grain très fin, veloutée et doux comme plume. Il ne laisse pas de traces de doigts et possède une résistance à la rayure supérieure à la moyenne. Cette finition est obtenue grâce à un processus artisanal exclusif. Après le processus de laquage classique, en fait, une peinture spéciale zero gloss est appliqué pour donner l'effet mat. En fin, tout est soumis à un processus de séchage.

HERMOSA AL TACTO - Lacado efecto Velluto

Para la colección Driadi, hemos reservado una laca suave al tacto con efecto VELLUTO disponible bajo pedido. El efecto a la vista es de una opacidad natural, mientras que al tacto da una agradable sensación de una superficie muy fina, aterciopelada y suave como una pluma, que no deja marcas y tiene una resistencia al rayado superior a la media. Este acabado se obtiene a través de un proceso artesanal exclusivo. Después del proceso de lacado clásico, de hecho, se aplica una pintura especial con brillo cero que le da una apariencia opaca. Finalmente, todo se somete a un proceso de secado.

COLLEZIONE KUADRA

Kuadra Collection

Collection Kuadra

Colección Kuadra

KU800

KU803

KU805

KU810

KU811

KU817

B System - Telaio B-UNO, B-DUE con anta complanare KO-ZERO rasoparete da un lato



*B-SYSTEM – support B-UNO and B-DUE frames with complanar door
and KO-ZERO flush on one side*

*B-SYSTEM – cadre de support B-UNO, B-DUE avec porte coplanaire
KO-ZERO à fleur de mur d'un côté*

*B-SYSTEM - marco B-UNO, B-DUE, con batiente
KO-ZERO alineado a la pared de un lado*

Cerniera registrabile a scomparsa e serratura magnetica



*Hidden adjustable hinges and magnetic lock
Charnières réglables cachées et serrure magnétique
Bisagra ajustable oculta y cerradura magnética*

KU800

*TORTORA
SISTEMA B-UNO*





KU803

*PANNA
SISTEMA KO-ZERO*

*SENZA FORO CHIAVE
(A RICHIESTA)*

*Without key hole (on request)
Sans trou de serrure (sur demande)
Sin agujero para llave (bajo pedido)*



KU805

*OCRA
SISTEMA B-DUE*

V810

*SISTEMA B-ZERO
ANTA VETRO
SATINATO BIANCO
CON DECORO
SABBIATO*

KU810

*BIANCO
SISTEMA B-UNO*

KU811

SALVIA
SISTEMA B-DUE



PARTICOLARE ANTA COMPLANARE

*Detail complanar door
Détail porte coplanaire
Detalle batiente*



V817

*SISTEMA B-ZERO
ANTA VETRO TRASPARENTE
CON DECORO SABBATO*

KU817

*OLIVA
SISTEMA B-DUE*

Finiture Kuadra

Kuadra finishes

Finitions Kuadra

Acabados Kuadra

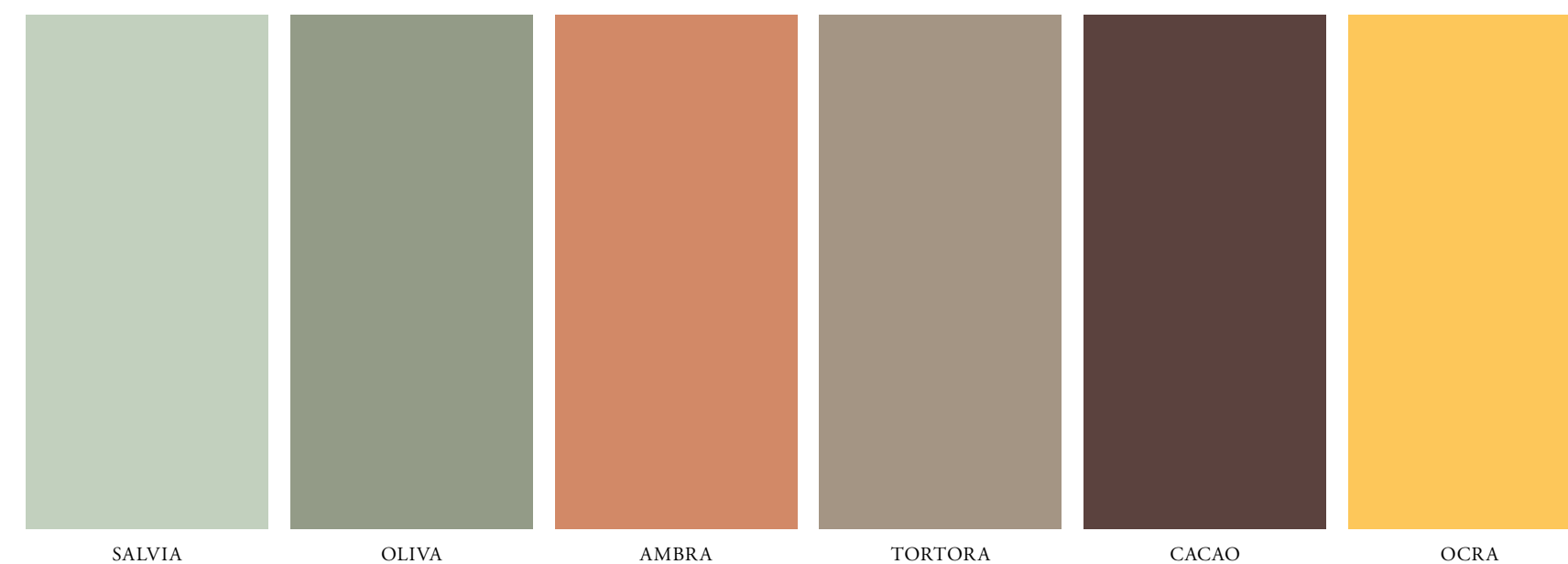
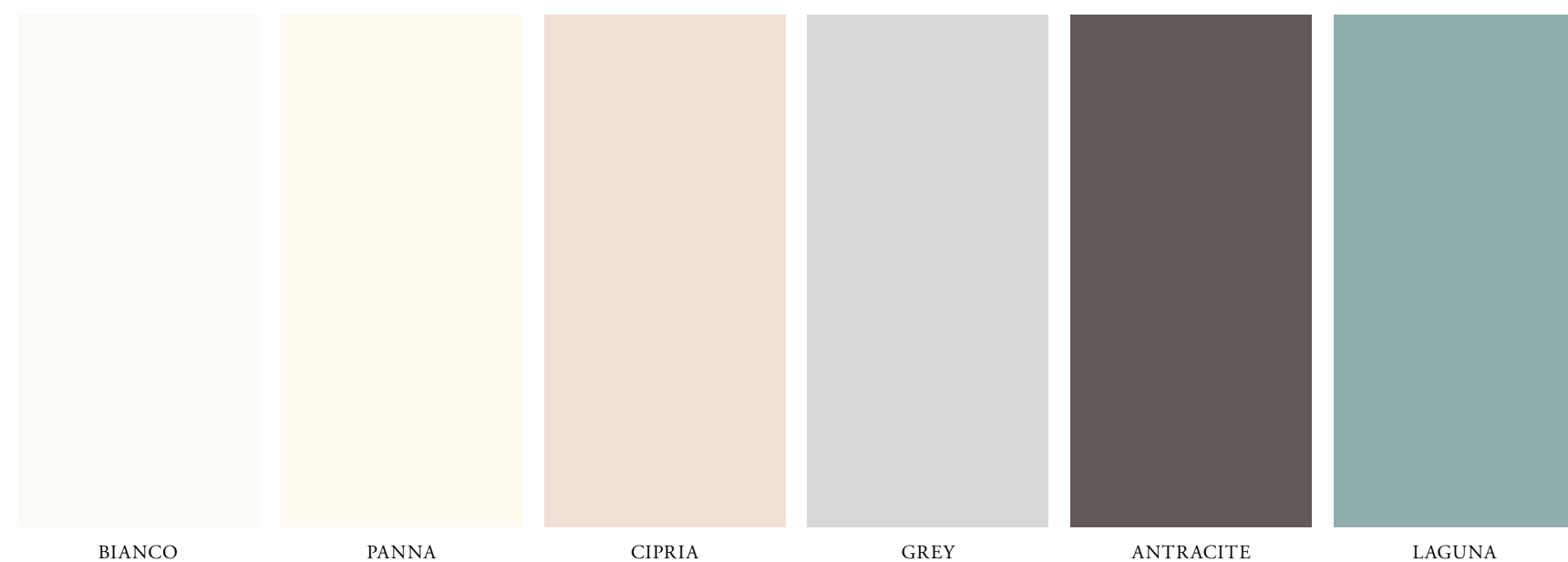

SCALA RAL O NCS A SCELTA

*RAL or NCS optional scale
Nuancier RAL ou NCS au choix
Carta de color RAL o NCS a elegir*

Verniciatura con prodotti ecologici idrosolubili (a base d'acqua)
Painting with water-soluble ecological products (water-based)
Peinture avec des produits écologiques solubles dans l'eau (à base d'eau)
Barnizado con productos ecológicos solubles en agua (a base de agua)

LACCATURA VELLUTO (a richiesta)
VELLUTO LACQUERING (on request)
LAQUÉ VELLUTO (sur demande)
LACA DE VELLUTO (bajo pedido)

Kuadra Sistemi di apertura

Opening systems

Systèmes d'ouverture

Sistemas de apertura



SISTEMA B-UNO: COMPLANARE A SPINGERE

*B-UNO system: coplanar on push side
Système B-UNO: coplanaire à pousser
Sistema B-UNO: a empujar*



SISTEMA B-DUE: COMPLANARE A TIRARE

*B-DUE system: coplanar on pull side
Système B-DUE: coplanaire à tirer
Sistema B-DUE: a tirar*

TELAIO IN ALLUMINIO

*Aluminum frame
Cadre en aluminium
Marco de aluminio*



SISTEMA KO-ZERO: COMPLANARE A SPINGERE

*KO-ZERO system: on push side
Système KO-ZERO: coplanaire à pousser
Sistema KO-ZERO: a empujar*



SISTEMA KO-ZERO: COMPLANARE A TIRARE

*KO-ZERO system: on pull side
Système KO-ZERO: coplanaire à tirer
Sistema KO-ZERO: a tirar*

Kuadra Accessori

Accessories

Accessoires

Accesorios



CERNIERA A SCOMPARSA
FORNITA DI SERIE

*Retractable hinge supplied as standard
Charnières invisibles fournies de série
Bisagra oculta suministrada de serie*

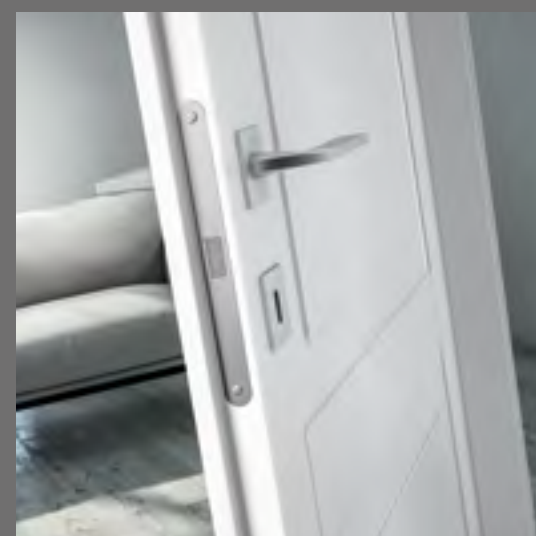

SERRATURA MAGNETICA
FORNITA DI SERIE

*Magnetic lock supplied as standard
Serrure magnétique fournie de série
Cerradura magnética suministrada de serie*



INCONTRO PER SERRATURA
MAGNETICA FORNITA DI SERIE

*Hook lock for magnetic lock
supplied as standard
Système de fermeture serrure
magnétique fourni de série
Ganchos para cerradura
magnética suministrados de serie*



KIT MANIGLIETTE TONDE CON SERRATURA
FORNITA DI SERIE PER SISTEMA SCORREVOLE
INTERNO MURO. SU RICHIESTA SERRATURA
PER SCORREVOLE ESTERNO MURO

*Round handle kit with lock supplied as standard for internal
sliding system. Lock on request for exterior wall sliding*

*Kit de poignées rondes avec serrure magnétique de série
pour système coulissant interne. Serrure sur demande
pour glissement de mur extérieur*

*Kit de manijas redondas suministrado de serie para sistemas
de puertas correderas interior pared. Disponible cerradura para
corredera exterior pared previa solicitud*



A RICHIESTA KIT MANIGLIETTE QUADRE
PER SISTEMA SCORREVOLE INTERNO
ED ESTERNO MURO. SU RICHIESTA SERRATURA
PER SCORREVOLE ESTERNO MURO

*On request square handle kit for interior and exterior wall sliding.
Lock on request for exterior wall sliding*

*Sur demande kit de poignées carrées pour coulissement
intérieur et mur extérieur. Verrou sur demande pour
glissement de mur extérieur*

*Kit de manijas cuadradas para sistemas de puertas correderas
interior y exterior pared. Disponible cerradura para corredera
exterior pared previa solicitud*

COLLEZIONE SOFT

Soft Collection

Collection Soft

Colección Soft

SO800

SO803

SO805

SO810

SO811

SO817

B System - Telaio B-UNO, B-DUE con anta complanare KO-ZERO rasoparete da un lato



*B-SYSTEM – support B-UNO and B-DUE frames with complanar door
and KO-ZERO flush on one side*

*B-SYSTEM – cadre de support B-UNO, B-DUE avec porte coplanaire
KO-ZERO à fleur de mur d'un côté*

*B-SYSTEM - marco B-UNO, B-DUE, con batiente
KO-ZERO alineado a la pared de un lado*

Cerniera registrabile a scomparsa e serratura magnetica

Hidden adjustable hinges and magnetic lock

Charnières réglables cachées et serrure magnétique

Bisagra ajustable oculta y cerradura magnética





SO800

*PORO APERTO PANNA
SISTEMA KO-ZERO*

*SENZA FORO CHIAVE
(A RICHIESTA)*

*Without key hole (on request)
Sans trou de serrure (sur demande)
Sin agujero para llave (bajo pedido)*



SO803/v

*SISTEMA B-UNO
CRISTALLO BASIC BIANCO*

SO803

*ANTRACITE
SISTEMA B-UNO*

SO805

*PORO APERTO BIANCO
SISTEMA B-DUE*

V805

*SISTEMA B-ZERO
ANTA VETRO SATINATO BIANCO
CON DECORO SABBBIATO*

SO810

*PORO APERTO TORTORA
SISTEMA B-UNO*



SO811

*PORO APERTO CIPRIA
SISTEMA KO-ZERO*

*SENZA FORO CHIAVE
(A RICHIESTA)*

*Without key hole (on request)
Sans trou de serrure (sur demande)
Sin agujero para llave (bajo pedido)*

V811

*SISTEMA B-ZERO
ANTA VETRO TRASPARENTE
CON DECORO SABBBIATO*

SO817

*PORO APERTO AMBRA
SISTEMA B-DUE*



Finiture Soft

Soft finishes

Finitions Soft

Acabados Soft



SCALA RAL O NCS A SCELTA

RAL or NCS optional scale
Nuancier RAL ou NCS au choix
Carta de color RAL o NCS a elegir

LACCATURA PORO APERTO DELL'ANTA

Lacquered open-pore door
Lacquerie poro ouverte
Panel lacado a poro abierto

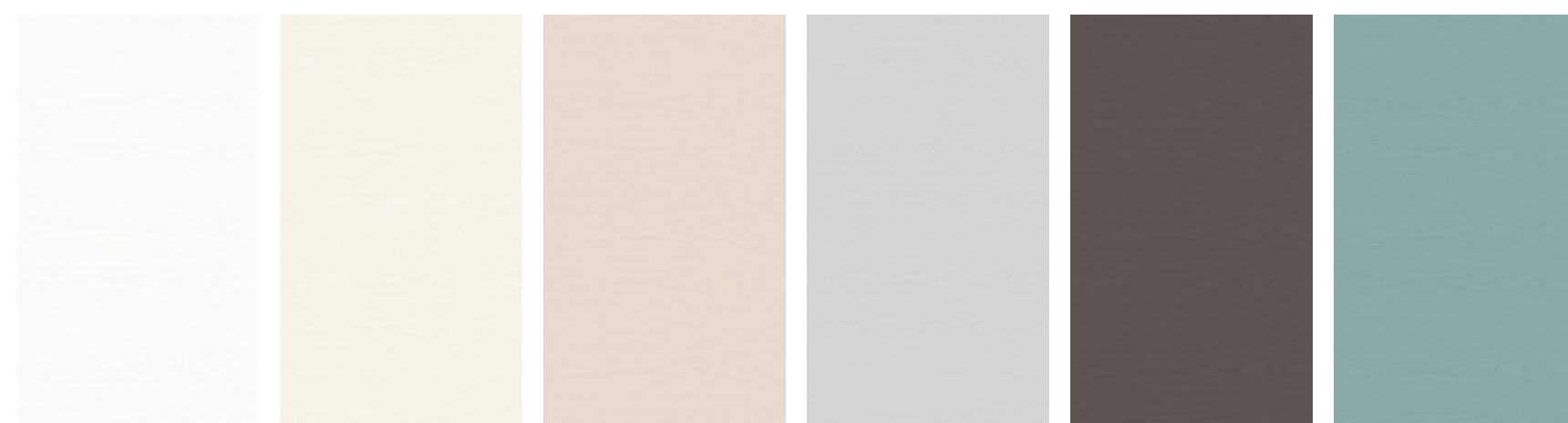

PORO APERTO BIANCO PORO APERTO PANNA PORO APERTO CIPRIA PORO APERTO GREY PORO APERTO ANTRACITE PORO APERTO LAGUNA



PORO APERTO SALVIA PORO APERTO OLIVA PORO APERTO AMBRA PORO APERTO TORTORA PORO APERTO CACAO PORO APERTO OCRA

LACCATURA TELAIO E COPRIFILI

Lacquered frame and architrave
Cadre laqué et architrave
Lacado marco y chambrana



BIANCO PANNA CIPRIA GREY ANTRACITE LAGUNA



SALVIA OLIVA AMBRA TORTORA CACAO OCRA

Soft Sistemi di apertura

Opening systems

Systèmes d'ouverture

Sistemas de apertura

TELAIO IN ALLUMINIO

*Aluminum frame
Cadre en aluminium
Marco de aluminio*



SISTEMA B-UNO: COMPLANARE A SPINGERE

*B-UNO system: coplanar on push side
Système B-UNO: coplanaire à pousser
Sistema B-UNO: a empujar*



SISTEMA B-DUE: COMPLANARE A TIRARE

*B-DUE system: coplanar on pull side
Système B-DUE: coplanaire à tirer
Sistema B-DUE: a tirar*

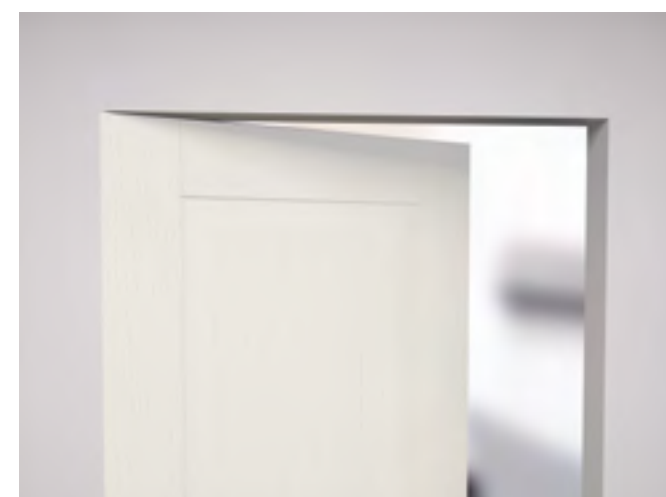

SISTEMA KO-ZERO: COMPLANARE A SPINGERE

*KO-ZERO system: on push side
Système KO-ZERO: coplanaire à pousser
Sistema KO-ZERO: a empujar*



SISTEMA KO-ZERO: COMPLANARE A TIRARE

*KO-ZERO system: on pull side
Système KO-ZERO: coplanaire à tirer
Sistema KO-ZERO: a tirar*

Soft Accessori

Accessories

Accessoires

Accesorios



CERNIERA A SCOMPARSA
FORNITA DI SERIE

*Retractable hinge supplied as standard
Charnières invisibles fournies de série
Bisagra oculta suministrada de serie*

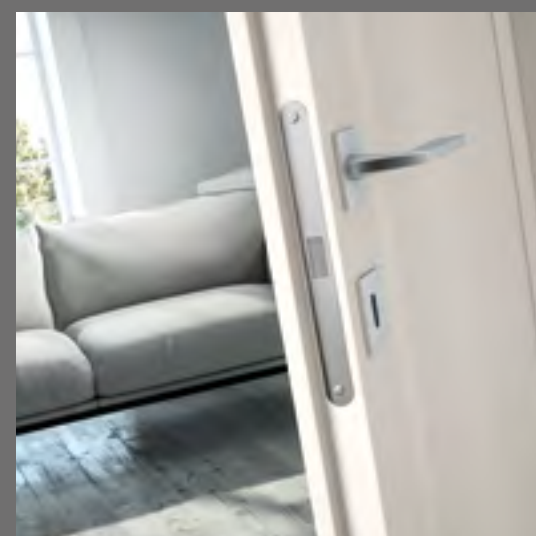

SERRATURA MAGNETICA
FORNITA DI SERIE

*Magnetic lock supplied as standard
Serrure magnétique fournie de série
Cerradura magnética suministrada de serie*



INCONTRO PER SERRATURA
MAGNETICA FORNITA DI SERIE

*Hook lock for magnetic lock
supplied as standard
Système de fermeture serrure
magnétique fourni de série
Ganchos para cerradura
magnética suministrados de serie*



KIT MANIGLIETTE TONDE CON SERRATURA
FORNITA DI SERIE PER SISTEMA SCORREVOLE
INTERNO MURO. SU RICHIESTA SERRATURA
PER SCORREVOLE ESTERNO MURO

*Round handle kit with lock supplied as standard for internal
sliding system. Lock on request for exterior wall sliding*

*Kit de poignées rondes avec serrure magnétique de série
pour système coulissant interne. Serrure sur demande
pour glissement de mur extérieur*

*Kit de manijas redondas suministrado de serie para sistemas
de puertas correderas interior pared. Disponible cerradura para
corredera exterior pared previa solicitud*



A RICHIESTA KIT MANIGLIETTE QUADRE
PER SISTEMA SCORREVOLE INTERNO
ED ESTERNO MURO. SU RICHIESTA SERRATURA
PER SCORREVOLE ESTERNO MURO

*On request square handle kit for interior and exterior wall sliding.
Lock on request for exterior wall sliding*

*Sur demande kit de poignées carrées pour coulissement
intérieur et mur extérieur. Verrou sur demande pour
glissement de mur extérieur*

*Kit de manijas cuadradas para sistemas de puertas correderas
interior y exterior pared. Disponible cerradura para corredera
exterior pared previa solicitud*

Kuadra e Soft

ANTE IN CRISTALLO TEMPERATO DI SICUREZZA,
BASE TRASPARENTE O SATINATA CON DECORI SABBIATI

Tempered safety glass doors, transparent base or satin with sandblasted decorations

Portes en cristal trempé de sécurité, base transparente ou à base de satin avec des décorations sablées

Puertas de seguridad de cristal templado, base transparente o satinada con decoraciones esmeriladas



V800

V803

V805

V810



V811

V817

*COLORI DISPONIBILI ANCHE SU
BASE TRASPARENTE (a richiesta)
Available colours also available on a transparent
support (on demand)
Couleurs disponibles également disponibles
sur une base transparente (sur demande)
Colours disponibles disponibles con vidrio
transparente también (bajo pedido)*

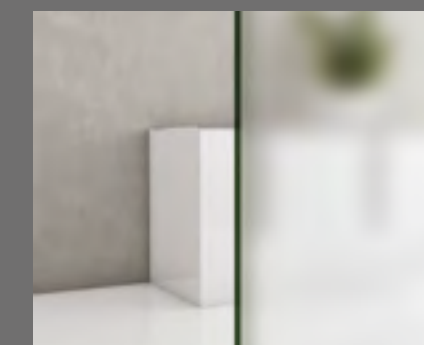

**CRISTALLO BASIC
SATINATO BIANCO (DI SERIE)**
*White Satin Basic Crystal (standard)
Cristal Basic De Satin Blanc (standard)
Cristal Basic Blanco Satinado (estándar)*

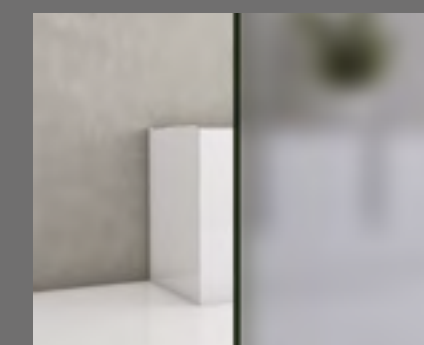

**CRISTALLO BASIC SATINATO
GRIGIO (SU RICHIESTA)**
*Grey Satin Basic Crystal (on demand)
Cristal Basic De Satin Gris (sur demand)
Cristal Basic Gris Satinado (previa solicitud)*

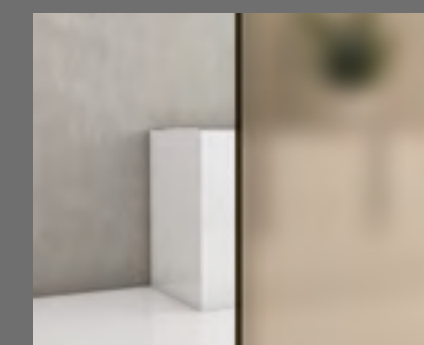

**CRISTALLO BASIC SATINATO
BRONZO (SU RICHIESTA)**
*Bronze Satin Basic Crystal (on demand)
Cristal Basic De Satin Bronce (sur demand)
Cristal Basic Bronce Satinado (previa solicitud)*

COLLEZIONE INCONTRI

Incontri Collection

Collection Incontri

Colección Incontri

IN400	IN422
IN401	IN423
IN403	IN424
IN404	IN425
IN405	IN426
IN406	IN427
IN407	IN RIM
IN420	IN RING
IN421	

B System - Telaio B-UNO, B-DUE con anta complanare KO-ZERO rasoparete da un lato



*B-SYSTEM – support B-UNO and B-DUE frames with complanar door
and KO-ZERO flush on one side*

*B-SYSTEM – cadre de support B-UNO, B-DUE avec porte coplanaire
KO-ZERO à fleur de mur d'un côté*

*B-SYSTEM - marco B-UNO, B-DUE, con batiente
KO-ZERO alineado a la pared de un lado*

Cerniera registrabile a scomparsa e serratura magnetica

Hidden adjustable hinges and magnetic lock

Charnières réglables cachées et serrure magnétique

Bisagra ajustable oculta y cerradura magnética



IN400

CACAO
SISTEMA B-UNO

IN400/v

CRISTALLO
BASIC BRONZO



IN401

*PANNA
SISTEMA B-UNO*



IN403

TORTORA
SISTEMA B-DUE



PARTICOLARE DELLANTA CON INCISIONE

*Detail of the door carved panel
Détail de la porte avec gravure
Detalle del panel con grabado*

V404

*SISTEMA B-ZERO
ANTA VETRO
SATINATO BIANCO
CON DECORO INCISO*

IN404

*BIANCO
SISTEMA B-UNO*



IN405

AMBRA
SISTEMA KO-ZERO

SENZA FORO CHIAVE
(A RICHIESTA)

Without key hole (on request)
Sans trou de serrure (sur demande)
Sin agujero para llave (bajo pedido)



IN406

OCRA
SISTEMA B-DUE



PARTICOLARE DELLANTA CON INCISIONE

*Detail of the door carved panel
Détail de la porte avec gravure
Detalle del panel con grabado*



IN407

BIANCO
SISTEMA B-UNO

V420

*SISTEMA B-ZERO
ANTA VETRO
SATINATO BIANCO
CON DECORO INCISO*

IN420

*LAGUNA
SISTEMA B-DUE*





IN421

*SALVIA
SISTEMA B-UNO*



IN422

*ANTRACITE
SISTEMA B-DUE*

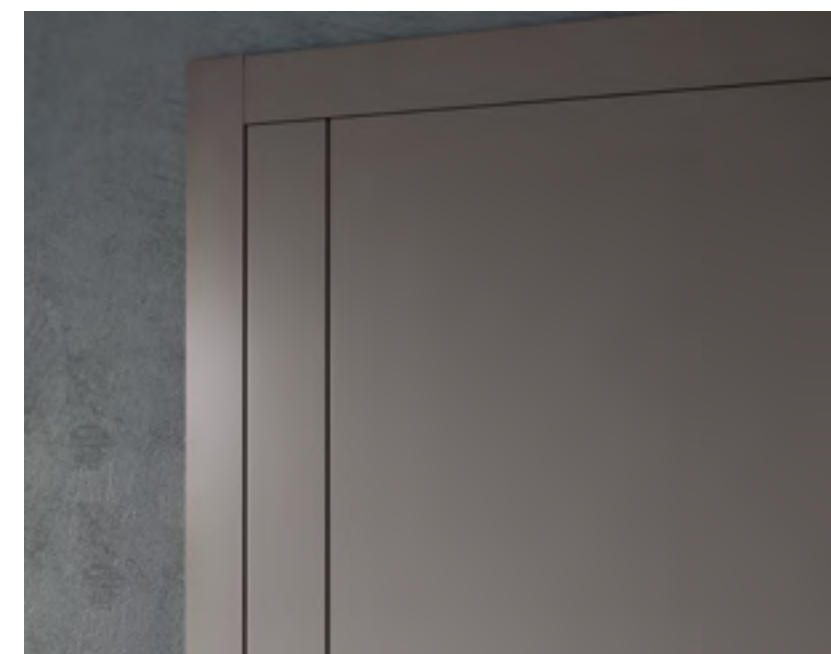

PARTICOLARE DELLANTA CON INCISIONE

*Detail of the carved panel
Détail de la porte avec gravure
Detalle del panel con grabado*



IN423

*TORTORA
SISTEMA B-UNO*

IN424

*CIPRIA
SISTEMA KO-ZERO*

*SENZA FORO CHIAVE
(A RICHIESTA)*

*Without key hole (on request)
Sans trou de serrure (sur demande)
Sin agujero para llave (bajo pedido)*



V425

*SISTEMA B-ZERO
ANTA VETRO TRASPARENTE
CON DECORO INCISO*

IN425

*BIANCO
SISTEMA B-DUE*





IN426

*LAGUNA
SISTEMA B-DUE*



IN427

PANNA
SISTEMA B-UNO



PARTICOLARE DELLANTA CON INCISIONE

*Detail of the carved panel
Détail de la porte avec gravure
Detalle del panel con grabado*

IN RIM

SALVIA
SISTEMA B-UNO





IN RING

*TORTORA
SISTEMA B-DUE*

Finiture Incontri

Incontri finishes

Finitions Incontri

Acabados Incontri

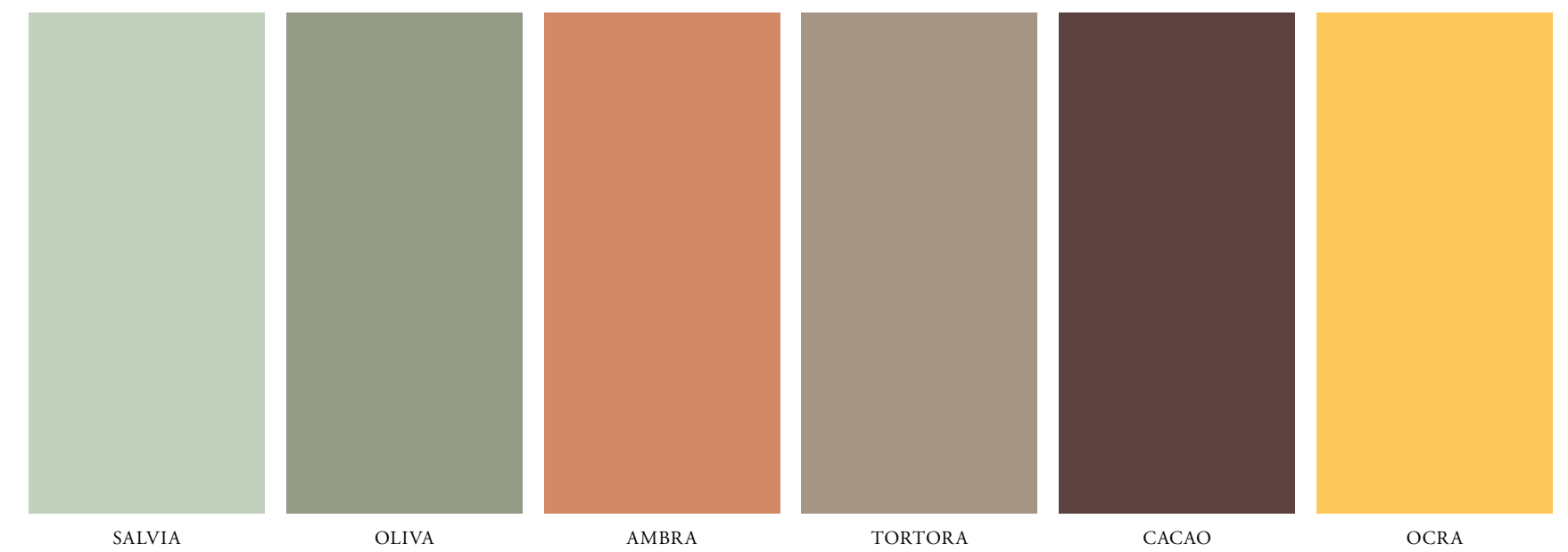
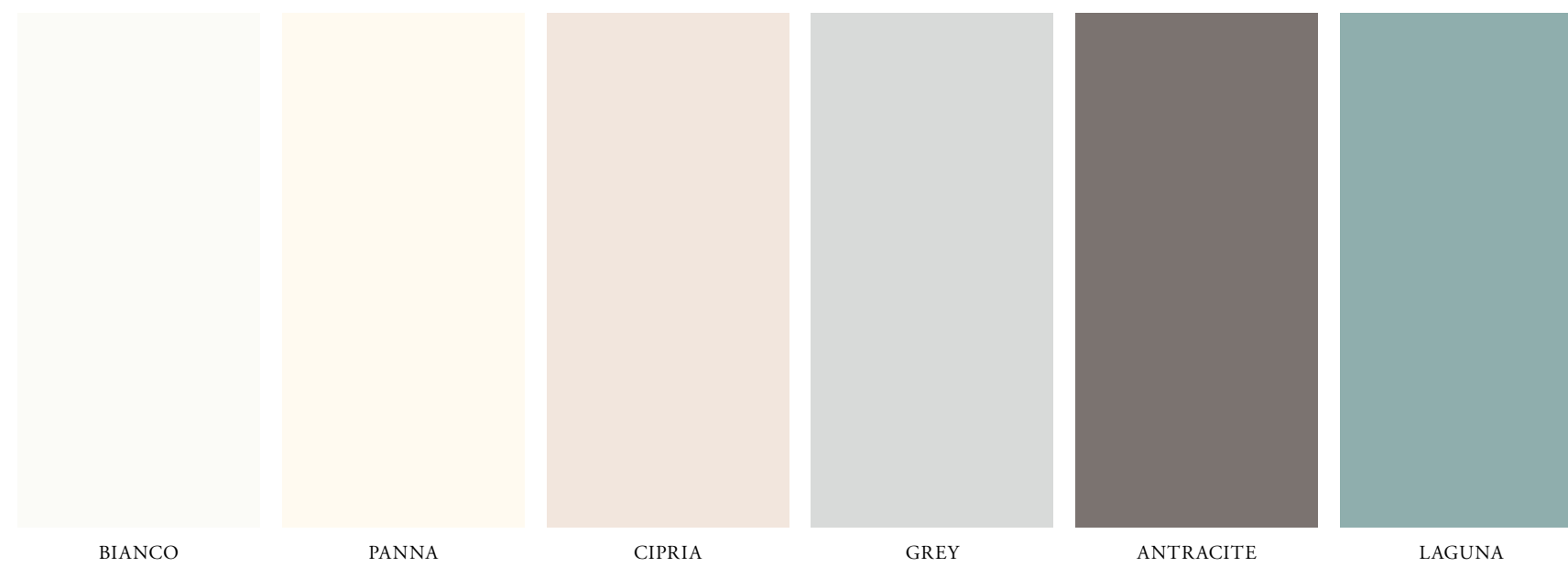

SCALA RAL O NCS A SCELTA

*RAL or NCS optional scale
Nuancier RAL ou NCS au choix
Carta de color RAL o NCS a elegir*

Verniciatura con prodotti ecologici idrosolubili (a base d'acqua)
Painting with water-soluble ecological products (water-based)
Peinture avec des produits écologiques solubles dans l'eau (à base d'eau)
Barnizado con productos ecológicos solubles en agua (a base de agua)

LACCATURA VELLUTO (a richiesta)
VELLUTO LACQUERING (on request)
LAQUÉ VELLUTO (sur demande)
LACA DE VELLUTO (bajo pedido)

Incontri Sistemi di apertura

Opening systems

Systèmes d'ouverture

Sistemas de apertura

TELAIO IN ALLUMINIO

*Aluminum frame
Cadre en aluminium
Marco de aluminio*



SISTEMA B-UNO: COMPLANARE A SPINGERE

*B-UNO system: coplanar on push side
Système B-UNO: coplanaire à pousser
Sistema B-UNO: a empujar*



SISTEMA B-DUE: COMPLANARE A TIRARE

*B-DUE system: coplanar on pull side
Système B-DUE: coplanaire à tirer
Sistema B-DUE: a tirar*



SISTEMA KO-ZERO: COMPLANARE A SPINGERE

*KO-ZERO system: on push side
Système KO-ZERO: coplanaire à pousser
Sistema KO-ZERO: a empujar*



SISTEMA KO-ZERO: COMPLANARE A TIRARE

*KO-ZERO system: on pull side
Système KO-ZERO: coplanaire à tirer
Sistema KO-ZERO: a tirar*

Incontri Accessori

Accessories

Accessoires

Accesorios



CERNIERA A SCOMPARSA
FORNITA DI SERIE

*Retractable hinge supplied as standard
Charnières invisibles fournies de série
Bisagra oculta suministrada de serie*



SERRATURA MAGNETICA
FORNITA DI SERIE

*Magnetic lock supplied as standard
Serrure magnétique fournie de série
Cerradura magnética suministrada de serie*

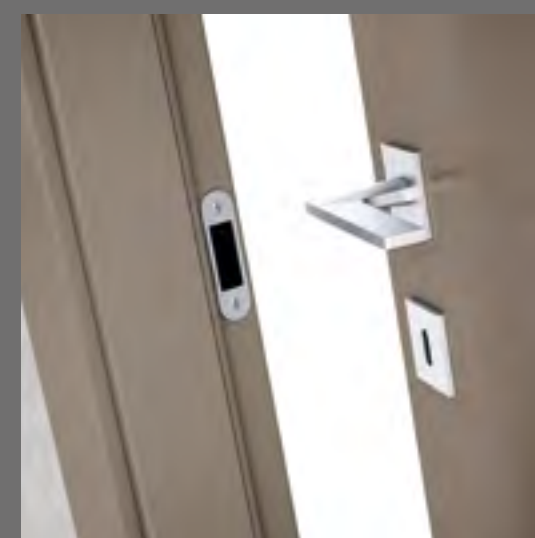

INCONTRO PER SERRATURA
MAGNETICA FORNITA DI SERIE

*Hook lock for magnetic lock
supplied as standard
Système de fermeture serrure
magnétique fourni de série
Ganchos para cerradura
magnética suministrados de serie*



KIT MANIGLIETTE TONDE CON SERRATURA
FORNITA DI SERIE PER SISTEMA SCORREVOLE
INTERNO MURO. SU RICHIESTA SERRATURA
PER SCORREVOLE ESTERNO MURO

*Round handle kit with lock supplied as standard for internal
sliding system. Lock on request for exterior wall sliding*

*Kit de poignées rondes avec serrure magnétique de série
pour système coulissant interne. Serrure sur demande
pour glissement de mur extérieur*

*Kit de manijas redondas suministrado de serie para sistemas
de puertas correderas interior pared. Disponible cerradura para
corredera exterior pared previa solicitud*



A RICHIESTA KIT MANIGLIETTE QUADRE
PER SISTEMA SCORREVOLE INTERNO
ED ESTERNO MURO. SU RICHIESTA SERRATURA
PER SCORREVOLE ESTERNO MURO

*On request square handle kit for interior and exterior wall sliding.
Lock on request for exterior wall sliding*

*Sur demande kit de poignées carrées pour coulissement
intérieur et mur extérieur. Verrou sur demande pour
glissement de mur extérieur*

*Kit de manijas cuadradas para sistemas de puertas correderas
interior y exterior pared. Disponible cerradura para corredera
exterior pared previa solicitud*

Incontri IN400-V/City

Incontri IN400/v

CRISTALLI SU BASE
TRASPARENTE O SATINATA

Glasses on transparent base or satin
Cristaux à base transparente ou à base de satin
Cristales en base transparente o satinada

**PARTICOLARE
DELLA VERSIONE A VETRO**

Detail of the glass model
Détail de la version en verre
Detalle de la versión con vidrio

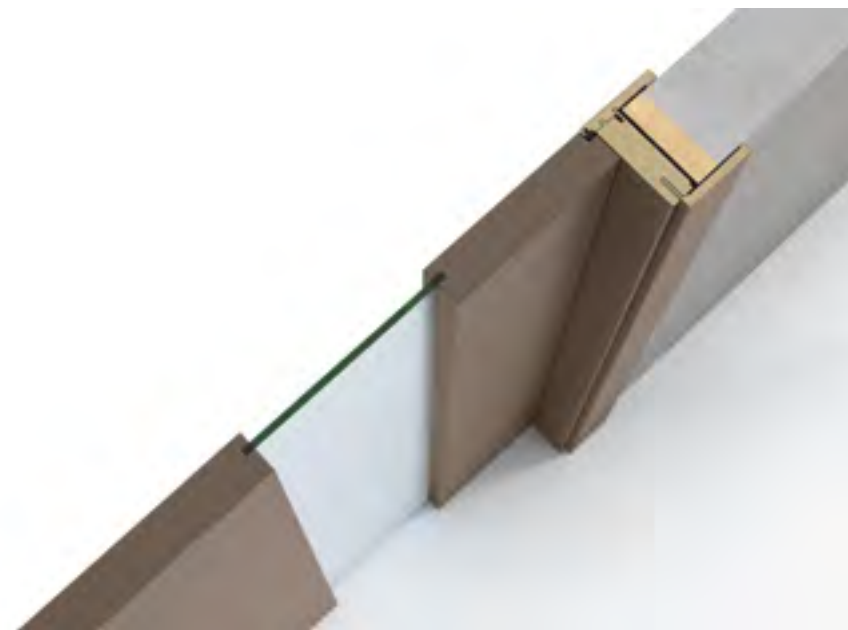

COLORI DISPONIBILI ANCHE SU BASE TRASPARENTE (a richiesta)

Available colours also available on a transparent support (on demand)
Colores disponibles également disponibles sur une base transparente (sur demande)
Couleurs disponibles disponibles con vidrio transparente también (bajo pedido)



**CRISTALLO NUVOLA BIANCO
(DI SERIE)**

White Nuvola Crystal (standard)
Cristal Nuvola Blanc (standard)
Cristal Nuvola Blanco (estándar)

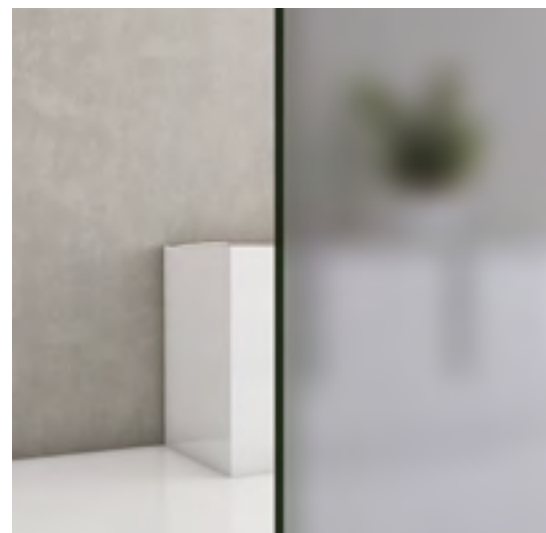

**CRISTALLO NUVOLA GRIGIO
(SU RICHIESTA)**

Grey Nuvola Crystal (on demand)
Cristal Nuvola Gris (sur demand)
Cristal Nuvola Gris (previa solicitud)



**CRISTALLO NUVOLA BRONZO
(SU RICHIESTA)**

Bronze Nuvola Crystal (on demand)
Cristal Nuvola Bronze (sur demand)
Cristal Nuvola Bronce (previa solicitud)



**CRISTALLO BASIC SATINATO BIANCO
(DI SERIE)**

White Satin Basic Crystal (standard)
Cristal Basic De Satin Blanc (standard)
Cristal Basic Blanco Satinado (estándar)



**CRISTALLO BASIC SATINATO GRIGIO
(SU RICHIESTA)**

Grey Satin Basic Crystal (on demand)
Cristal Basic De Satin Gris (sur demand)
Cristal Basic Gris Satinado (previa solicitud)

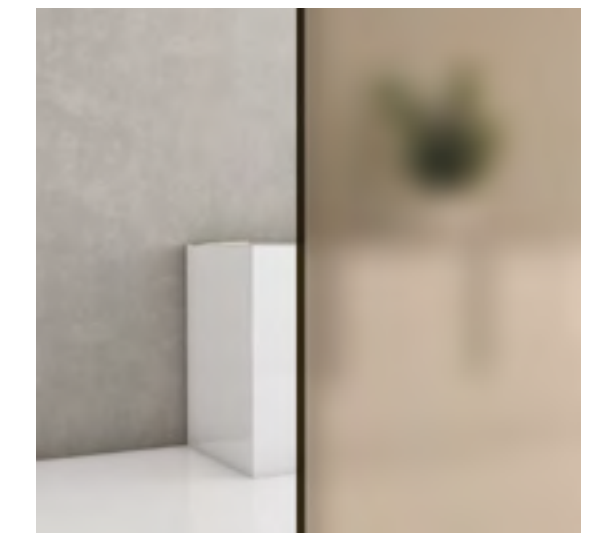

**CRISTALLO BASIC SATINATO BRONZO
(SU RICHIESTA)**

Bronze Satin Basic Crystal (on demand)
Cristal Basic De Satin Bronze (sur demand)
Cristal Basic Bronce Satinado (previa solicitud)

Incontri

ANTE IN CRISTALLO TEMPERATO DI SICUREZZA,
BASE SATINATA O TRASPARENTE CON INCISIONI LUCIDE

*Tempered safety glass doors,
transparent base or satin with glossy engravings*

*Portes en cristal trempé de sécurité,
base satinée ou transparente avec gravures brillantes*

*Puertas de seguridad de cristal templado,
base transparente o satinada con grabados brillantes*

COLORI DISPONIBILI ANCHE SU BASE TRASPARENTE (a richiesta)

*Available colours also available on a transparent support (on demand)
Colores disponibles également disponibles sur une base transparente (sur demande)
Colours disponibles disponibles con vidrio transparente también (bajo pedido)*



CRISTALLO BASIC SATINATO BIANCO
(DI SERIE)

*White Satin Basic Crystal (standard)
Cristal Basic De Satin Blanc (standard)
Cristal Basic Blanco Satinado (estándar)*



CRISTALLO BASIC SATINATO GRIGIO
(SU RICHIESTA)

*Grey Satin Basic Crystal (on demand)
Cristal Basic De Satin Gris (sur demande)
Cristal Basic Gris Satinado (previa solicitud)*



CRISTALLO BASIC SATINATO BRONZO
(SU RICHIESTA)

*Bronze Satin Basic Crystal (on demand)
Cristal Basic De Satin Bronze(sur demande)
Cristal Basic Bronce Satinado (previa solicitud)*

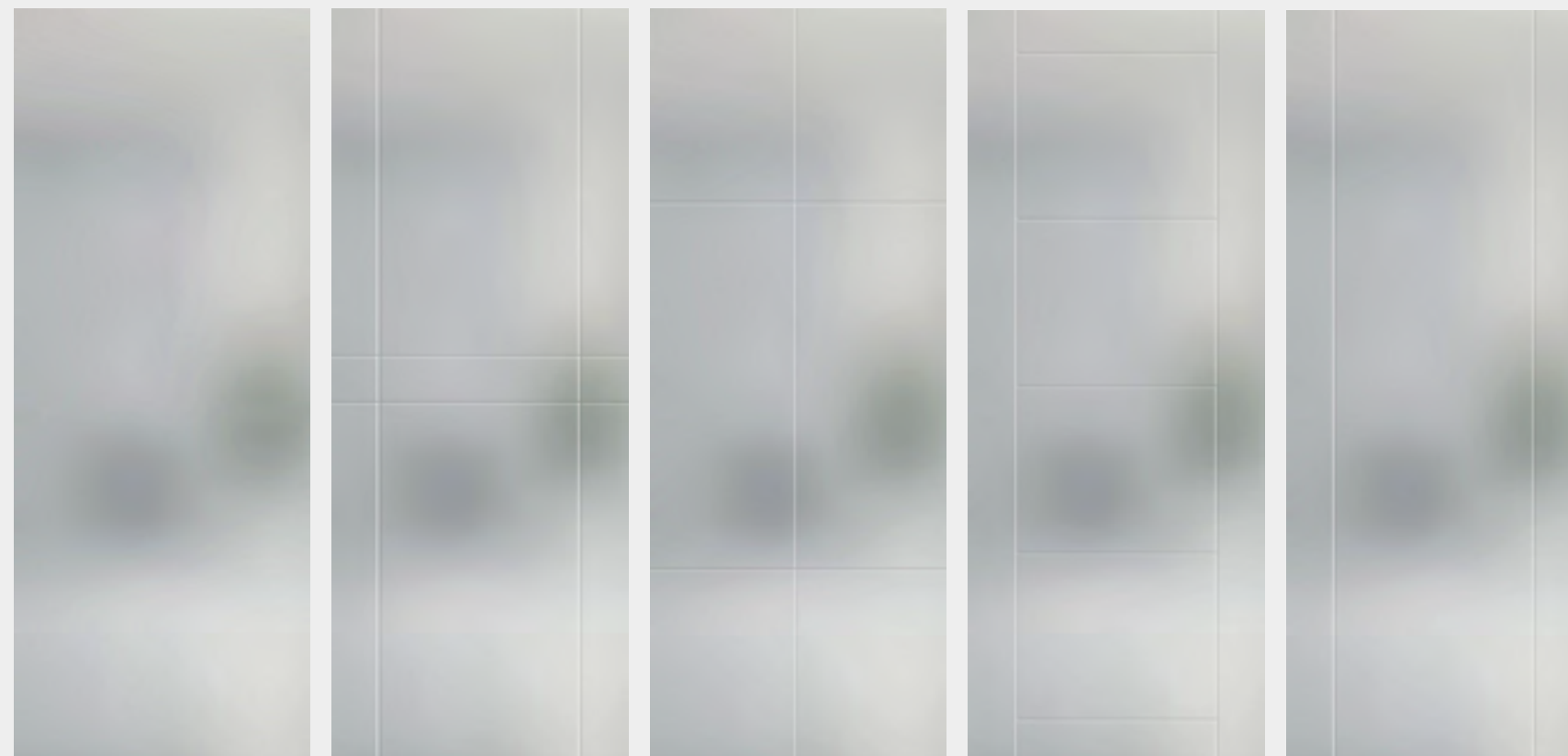

V400

V401

V403

V404

V405

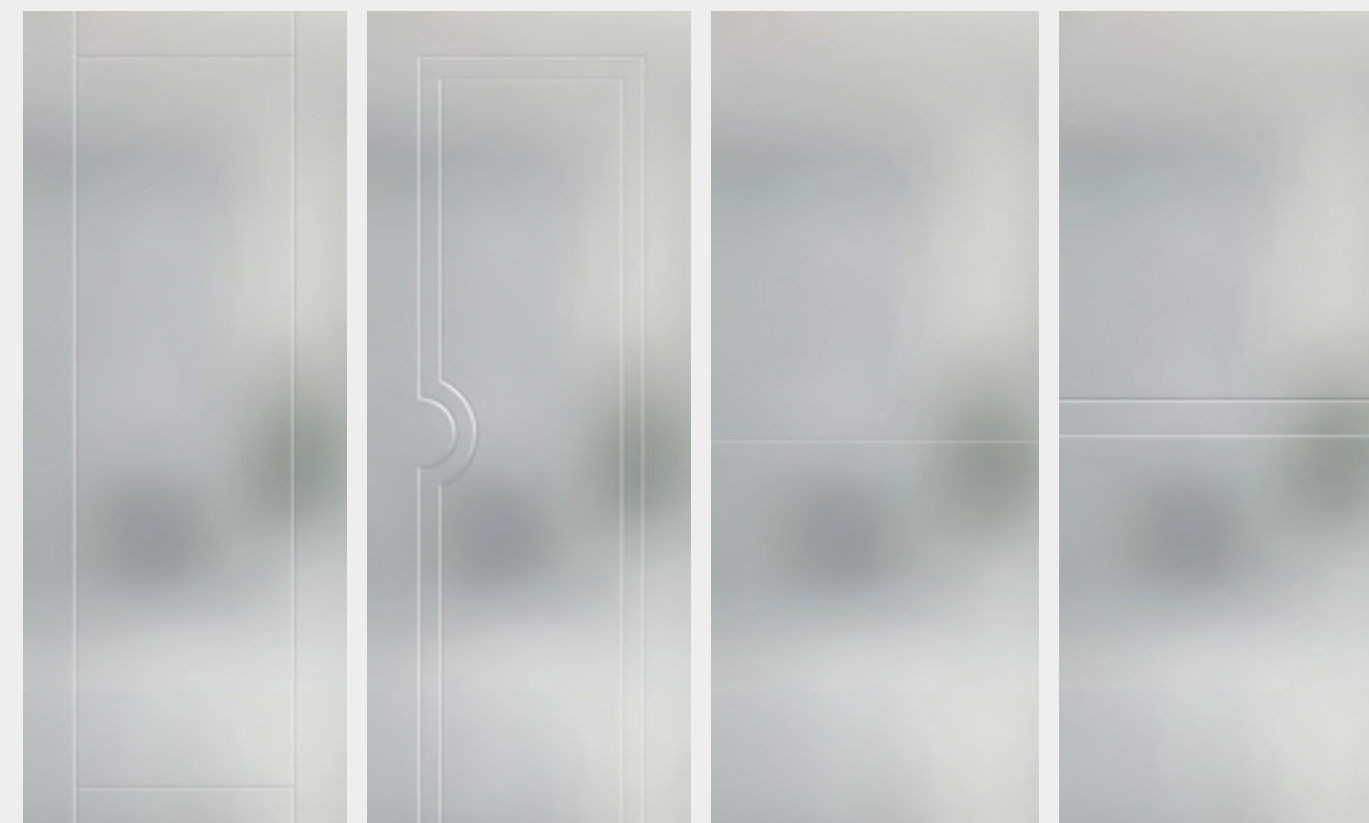

V406

V407

V420

V421

Incontri

ANTE IN CRISTALLO TEMPERATO DI SICUREZZA,
BASE SATINATA O TRASPARENTE CON INCISIONI LUCIDE

*Tempered safety glass doors,
transparent base or satin with glossy engravings*

*Portes en cristal trempé de sécurité,
base satinée ou transparente avec gravures brillantes*

*Puertas de seguridad de cristal templado,
base transparente o satinada con grabados brillantes*



V422

V423

V424

V425



V426

V427

VRIM

VRING

COLLEZIONE LIGHT

Light Collection

Collection Ligth

Colección Light

LI800

LI803

LI900

B-System - telaio B-ZERO con coprifilo telescopico

B-System - B-ZERO frame with telescopic architrave

B-System - Cadre B-ZERO avec habillage télescopique

B-System - Marco B-Zero con chambranas telescópicas



Cerniere anuba e serratura magnetica

Anuba hinges and magnetic lock

Charnières anuba et serrure magnétique

Bisagra anuba y cerradura magnética





LI800

BIANCO



PARTICOLARE PANTOGRAFATURA DELL'ANTA

*Detail of the pantograph panel
Pantographe particulière de la porte
Detalle del panel pantografiado*



LI803

PANNA

LI900

ANTRACITE

LI900/v

*CRISTALLO BASIC
BIANCO*

Finiture Light

Light Finishes

Finitions Light

Acabados Light

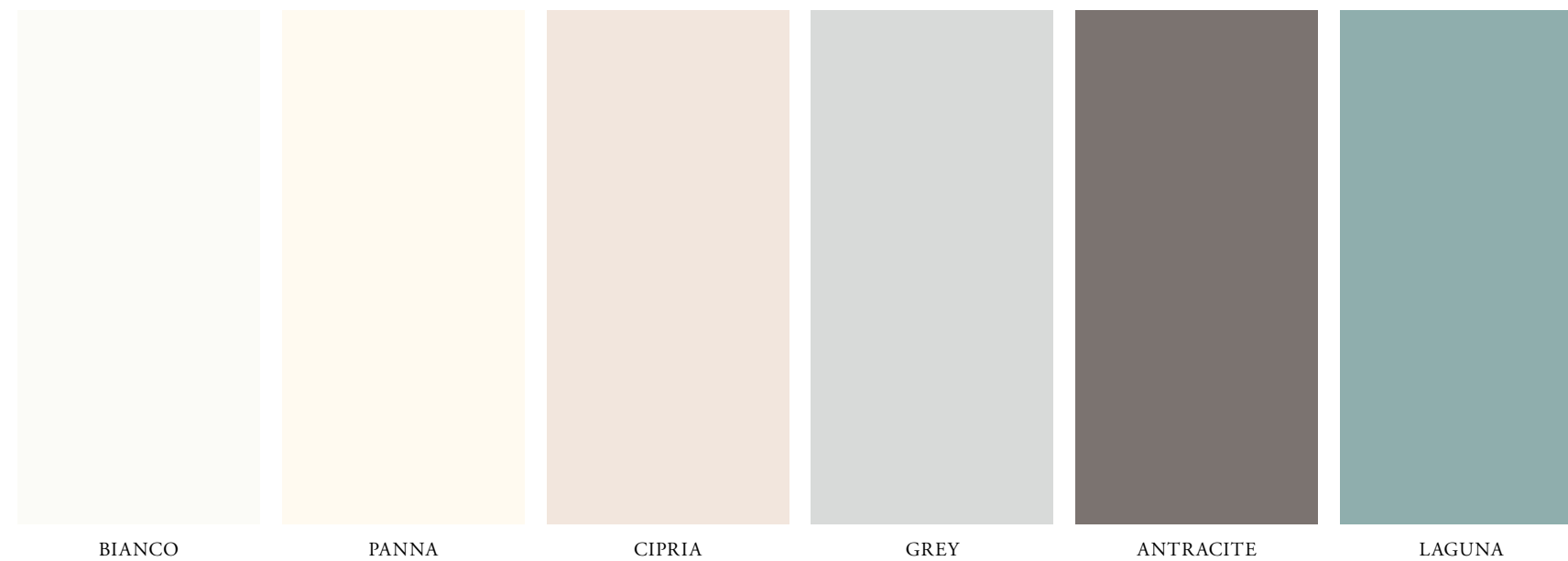

SCALA RAL O NCS A SCELTA

*RAL or NCS optional scale
Nuancier RAL ou NCS au choix
Carta de color RAL o NCS a elegir*

Verniciatura con prodotti ecologici idrosolubili (a base d'acqua)
Painting with water-soluble ecological products (water-based)
Peinture avec des produits écologiques solubles dans l'eau (à base d'eau)
Barnizado con productos ecológicos solubles en agua (a base de agua)

LACCATURA VELLUTO (a richiesta)
VELLUTO LACQUERING (on request)
LAQUÉ VELLUTO (sur demande)
LACA DE VELLUTO (bajo pedido)

Light Accessori

Accessories

Accessoires

Accesorios



PARTICOLARE TELAIO B-ZERO
CON CERNIERA ANUBA

Detail support B-ZERO frame with anuba hinges

Détail cadre de support B-ZERO avec charnières anuba

Detalle marco B-ZERO con bisagra anuba

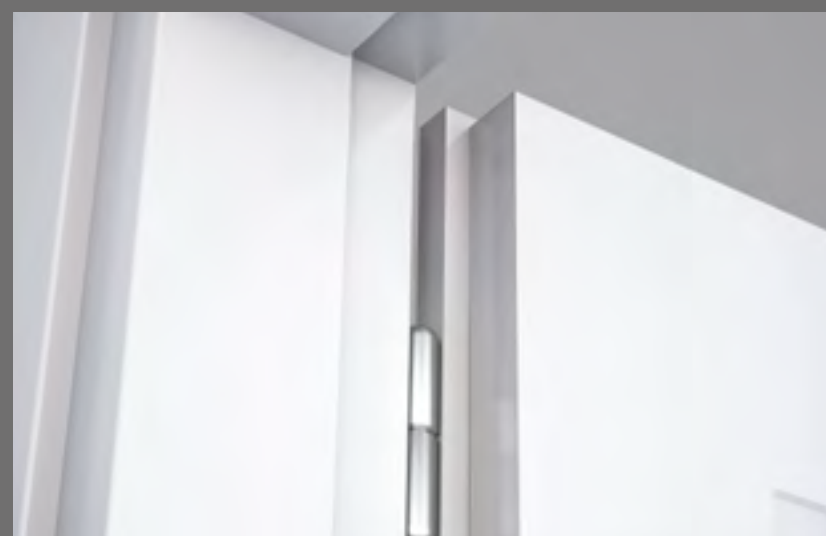

PARTICOLARE TELAIO B-ZERO
CON CERNIERA ANUBA

Detail support B-ZERO frame with anuba hinges

Détail cadre de support B-ZERO avec charnières anuba

Detalle marco B-ZERO con bisagra anuba



SERRATURA MAGNETICA FORNITA DI SERIE

Magnetic lock supplied as standard

Serrure magnétique fournie de série

Cerradura magnética suministrada de serie



INCONTRO PER SERRATURA MAGNETICA
FORNITA DI SERIE

Hook lock for magnetic lock supplied as standard

Système de fermeture serrure magnétique fourni de série

Ganchos para cerradura magnética suministrados de serie

Light Accessori

Accessories

Accessoires

Accesorios



KIT MANIGLIETTE TONDE CON SERRATURA
FORNITA DI SERIE PER SISTEMA SCORREVOLE
INTERNO MURO. SU RICHIESTA SERRATURA
PER SCORREVOLE ESTERNO MURO.

*Round handle kit with lock supplied as standard for internal
sliding system. Lock on request for exterior wall sliding.*

*Kit de poignées rondes avec serrure magnétique de série
pour système coulissant interne. Serrure sur demande pour
glissement de mur extérieur.*

*Kit de manijas redondas suministrado de serie para sistemas
de puertas correderas interior pared. Disponible cerradura para
corredera exterior pared previa solicitud.*



A RICHIESTA KIT MANIGLIETTE QUADRE
PER SISTEMA SCORREVOLE INTERNO
ED ESTERNO MURO. SU RICHIESTA SERRATURA
PER SCORREVOLE ESTERNO MURO.

*On request square handle kit for interior and exterior wall sliding.
Lock on request for exterior wall sliding.*

*Sur demande kit de poignées carrées pour coulissement
intérieur et mur extérieur. Verrou sur demande pour
glissement de mur extérieur.*

*Kit de manijas cuadradas para sistemas de puertas correderas
interior y exterior pared. Disponible cerradura para corredera
exterior pared previa solicitud.*

Light CRISTALLI SU BASE TRASPARENTE O SATINATA

Glasses on transparent base or satin

Cristaux à base transparente ou à base de satin

Cristales en base transparente o satinada

COLORI DISPONIBILI ANCHE SU BASE TRASPARENTE (a richiesta)

*Available colours also available on a transparent support (on demand)
Colores disponibles également disponibles sur une base transparente (sur demande)
Couleurs disponibles disponibles con vidrio transparente también (bajo pedido)*

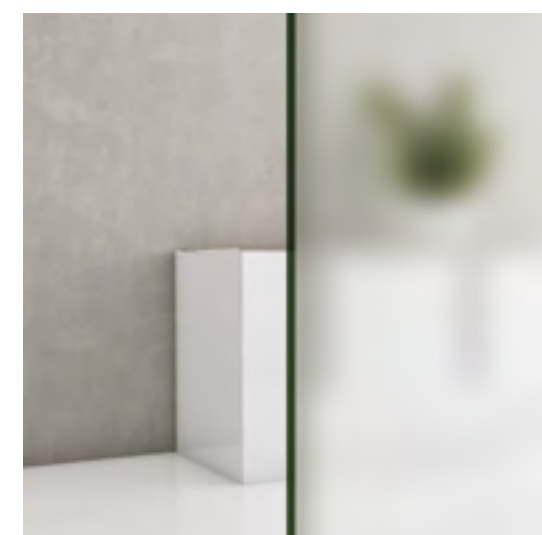

CRISTALLO BASIC SATINATO BIANCO
(DI SERIE)

*White Satin Basic Crystal (standard)
Cristal Basic De Satin Blanc (standard)
Cristal Basic Blanco Satinado (estándar)*

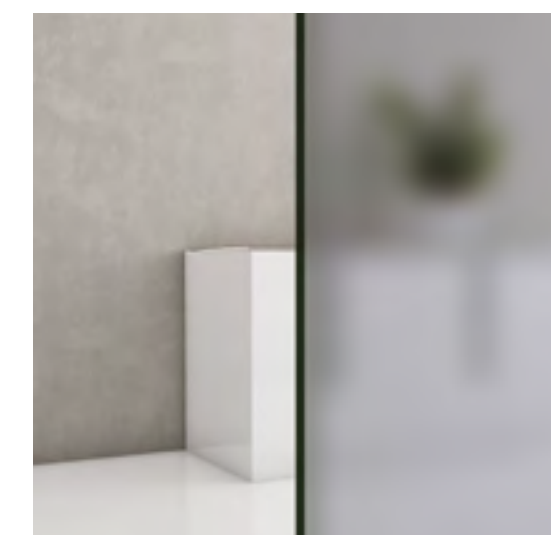

CRISTALLO BASIC SATINATO GRIGIO
(SU RICHIESTA)

*Grey Satin Basic Crystal (on demand)
Cristal Basic De Satin Gris (sur demand)
Cristal Basic Gris Satinado (previa solicitud)*

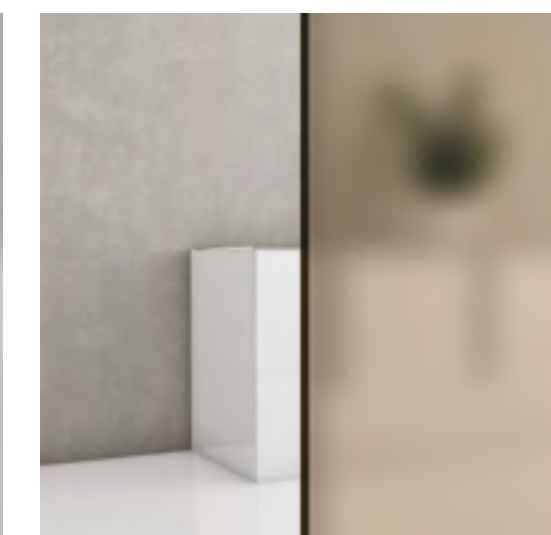

CRISTALLO BASIC SATINATO BRONZO
(SU RICHIESTA)

*Bronze Satin Basic Crystal (on demand)
Cristal Basic De Satin Bronze (sur demand)
Cristal Basic Bronce Satinado (previa solicitud)*

COLLEZIONE METRICA

Metrica Collection

Collection Metrica

Colección Métrica

ME100

ME101

ME102

ME103

ME105

ME106

ME107

ME108

ME109

ME110

ME111

ME114

ME115

B-System - telaio B-ZERO con coprifilo telescopico

B-System - B-ZERO frame with telescopic architrave

B-System - Cadre B-ZERO avec habillage télescopique

B-System - Marco B-Zero con chambranas telescópicas



Cerniere anuba e serratura magnetica

Anuba hinges and magnetic lock

Charnières anuba et serrure magnétique

Bisagra anuba y cerradura magnética





ME100

BIANCO



ME101/v

*CIPRIA
CRISTALLO SATINATO BIANCO
MODELLO BUD*



PARTICOLARE PANTOGRAFATURA DELL'ANTA

*Detail of the pantograph panel
Pantographe particulière de la porte
Detalle del panel pantografiado*



ME102

PANNA



*PARTICOLARE PANTOGRAFATURA
CON INCISIONE RINNOVA A RICHIESTA*

*Detail of the pantograph panel and carving Rinnova available on demand
Détail de la gravure Rinnova sur demande
Detalle de puerta pantografiada y grabado Rinnova*



ME103

CACAO



ME105

PANNA

ME106

GREY



ME107

BIANCO





ME108

TORTORA



ME109

OLIVA



ME110/i

*BIANCO
CRISTALLO BASIC
SATINATO BIANCO*

ME111/v

*LAGUNA
CRISTALLO BASIC
SATINATO BIANCO*

ME111

LAGUNA





ME114

PANNA



ME115

OCRA

PARTICOLARE PANTOGRAFATURA DELL'ANTA

*Detail of the pantograph panel
Pantographe particulière de la porte
Detalle del panel pantografiado*



Finiture Metrica

Metrica finishes

Finitions Metrica

Acabados Metrica

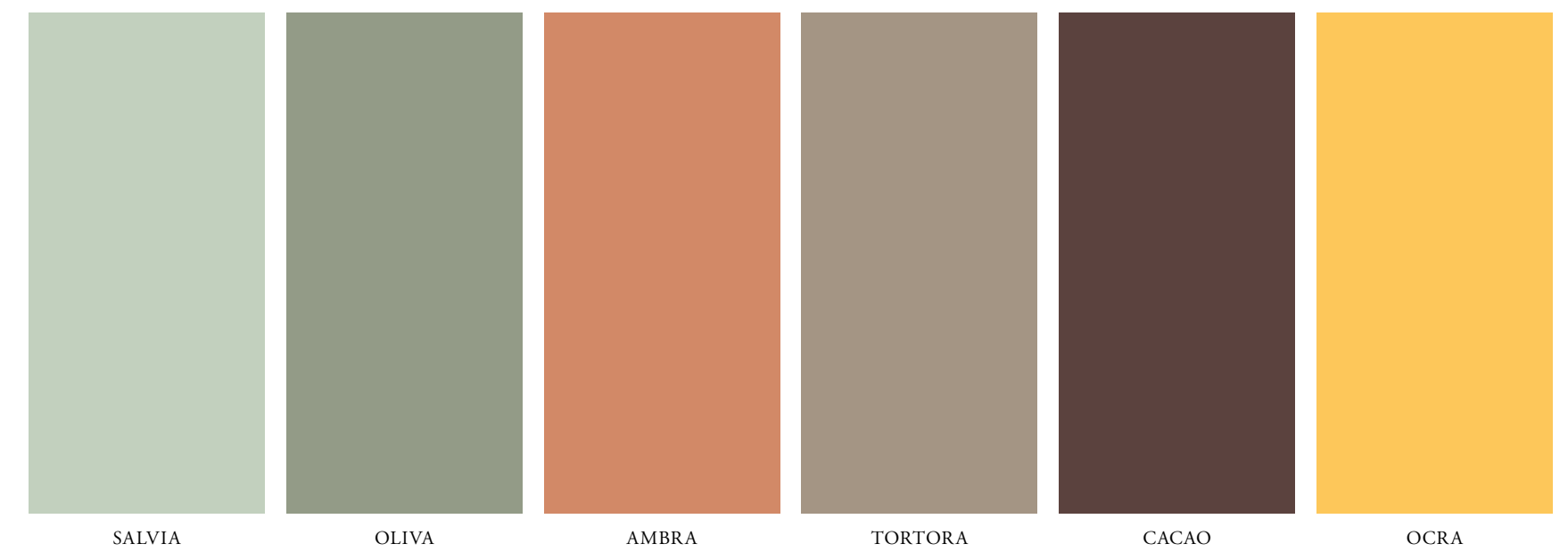
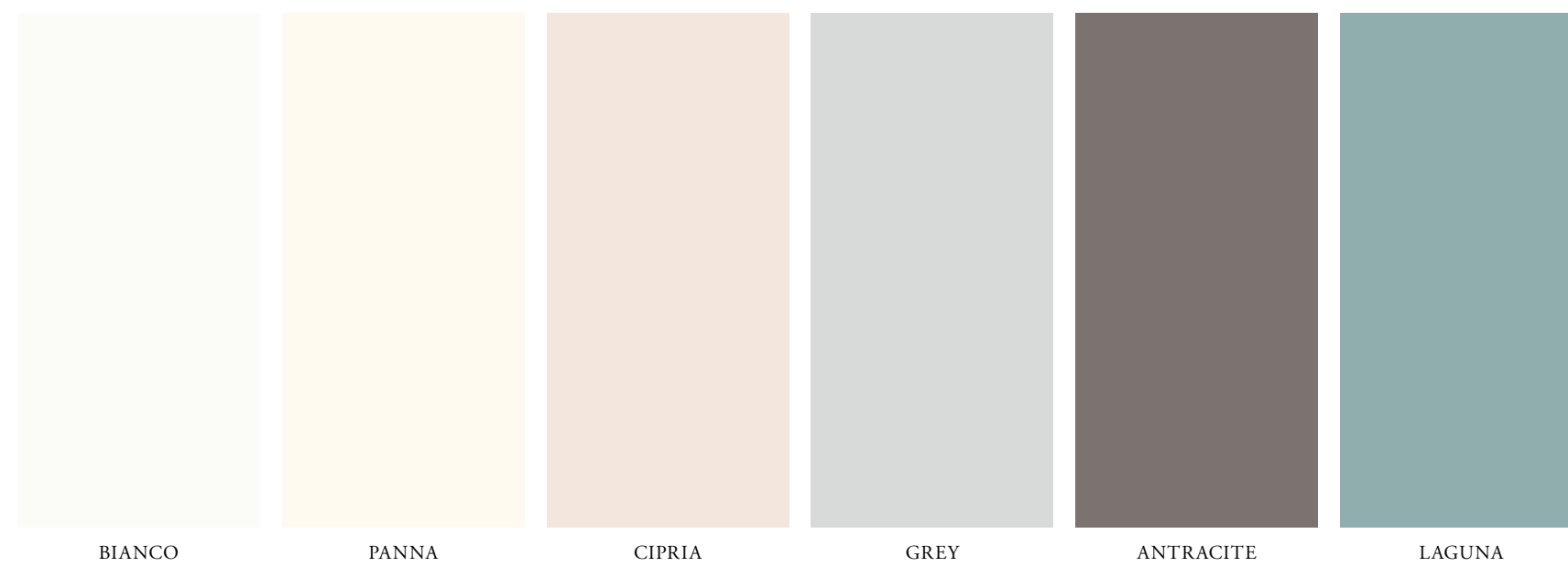

SCALA RAL O NCS A SCELTA

*RAL or NCS optional scale
Nuancier RAL ou NCS au choix
Carta de color RAL o NCS a elegir*

Verniciatura con prodotti ecologici idrosolubili (a base d'acqua)
Painting with water-soluble ecological products (water-based)
Peinture avec des produits écologiques solubles dans l'eau (à base d'eau)
Barnizado con productos ecológicos solubles en agua (a base de agua)

LACCATURA VELLUTO (a richiesta)
VELLUTO LACQUERING (on request)
LAQUÉ VELLUTO (sur demande)
LACA DE VELLUTO (bajo pedido)

Metrica Incisione Rinnova

Carving Rinnova

Engraving Rinnova

Grabado Rinnova



SU RICHIESTA INCISIONE RINNOVA
(per tutti i modelli Metrica)

*Carving Rinnova available on demand
(all Metrica models)
Engraving Rinnova on request
(pour tous les modèles Metrica)
Grabado Rinnova disponible previa solicitud
(para todos los modelos Metrica)*



Metrica Sistemi di Apertura

Opening systems

Systèmes d'ouverture

Sistemas de apertura



PARTICOLARE TELAIO B-ZERO
CON CERNIERA ANUBA (a spingere)

*Detail support B-ZERO frame with Anuba hinges (to push)
Détail cadre de support B-ZERO avec Charnières Anuba (pousser)
Detalle marco B-ZERO con Bisagra Anuba (a empujar)*



PARTICOLARE TELAIO B-ZERO
CON CERNIERA ANUBA (a tirare)

*Detail support B-ZERO frame with Anuba hinges (to pull)
Détail cadre de support B-ZERO avec Charnières Anuba (tirer)
Detalle marco B-ZERO con Bisagra Anuba (a tirar)*

Metrica Accessori

Accessories

Accessoires

Accesorios



SERRATURA MAGNETICA FORNITA DI SERIE

Magnetic lock supplied as standard

Serrure magnétique fournie de série

Cerradura magnética suministrada de serie



INCONTRO PER SERRATURA MAGNETICA FORNITA DI SERIE

*Hook lock for magnetic lock
supplied as standard*

*Système de fermeture serrure
magnétique fourni de série*

*Ganchos para cerradura
magnética suministrados de serie*



KIT MANIGLIETTE TONDE CON SERRATURA FORNITA DI SERIE PER SISTEMA SCORREVOLE INTERNO MURO. SU RICHIESTA SERRATURA PER SCORREVOLE ESTERNO MURO

*Round handle kit with lock supplied as standard for internal
sliding system. Lock on request for exterior wall sliding*

*Kit de poignées rondes avec serrure magnétique de série
pour système coulissant interne. Serrure sur demande pour
glissement de mur extérieur*

*Kit de manijas redondas suministrado de serie para sistemas
de puertas correderas interior pared. Disponible cerradura para
corredera exterior pared previa solicitud*



A RICHIESTA KIT MANIGLIETTE QUADRE PER SISTEMA SCORREVOLE INTERNO ED ESTERNO MURO. SU RICHIESTA SERRATURA PER SCORREVOLE ESTERNO MURO

*On request square handle kit for interior and exterior wall sliding.
Lock on request for exterior wall sliding*

*Sur demande kit de poignées carrées pour coulissement
intérieur et mur extérieur. Verrou sur demande pour
glissement de mur extérieur*

*Kit de manijas cuadradas para sistemas de puertas correderas
interior y exterior pared. Disponible cerradura para corredera
exterior pared previa solicitud*

COLLEZIONE ARMONIA

Armonia Collection

Collection Armonia

Colección Armonia

AR300

AR301

AR302

AR303

AR304

AR305

AR306

B-System - telaio B-ZERO con coprifilo telescopico

B-System - B-ZERO frame with telescopic architrave

B-System - Cadre B-ZERO avec habillage télescopique

B-System - Marco B-Zero con chambranas telescópicas



Cerniere anuba e serratura magnetica

Anuba hinges and magnetic lock

Charnières anuba et serrure magnétique

Bisagra anuba y cerradura magnética



AR300

ANTRACITE





AR301

TORTORA



*PARTICOLARE PANTOGRAFATURA E CAPITELLO C1
(A RICHIESTA)*

*Detail of the pantograph panel and capital C1 (on demand)
Pantographie particulier et capital C1 (sur demande)
Detalle del panel pantografiado y capitel C1 (previa solicitud)*



AR302/v

BIANCO
CRISTALLO SATINATO
BIANCO MODELLO NACRE'



PARTICOLARE COPRIFILO LIBERTY A RICHIESTA

*Detail architraves Liberty on demand
Détail du rideau Liberty sur demande
Detalle chambranas Liberty previa solicitud*



AR303

CIPRIA





AR304

*PANNA
CON CAPITELLO C3
(A RICHIESTA)*

*Capital C3 on demand
Capital C3 sur demande
Capitel C3 previa solicitud*



AR305/v

BIANCO
CRISTALLO SATINATO BIANCO
MODELLO NACRÈ





AR306

*PANNA
CAPITELLO C2
E COPRIFILO M50
A RICHIESTA*

*Capital C3 and architraves M50 on demand
Capitel C3 et garnitures M50 sur demande
Capitel C3 y chambranas M50 previa solicitud*

Finiture Armonia

Armonia finishes

Finitions Armonia

Acabados Armonia

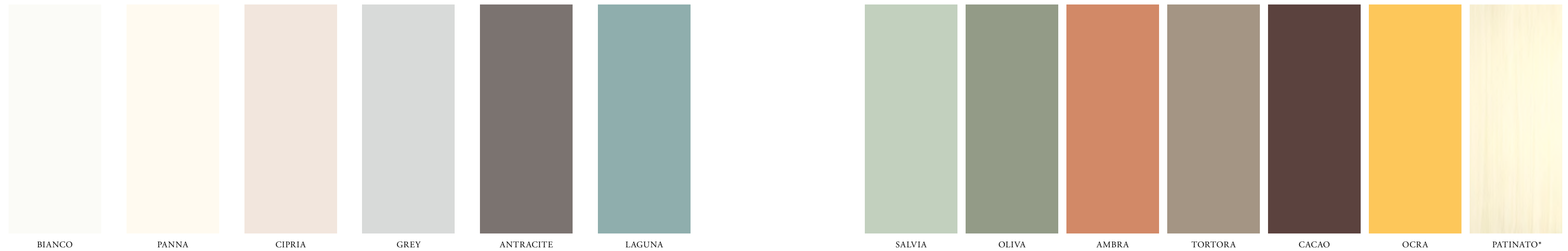

SCALA RAL O NCS A SCELTA

RAL or NCS optional scale
Nuancier RAL ou NCS au choix
Carta de color RAL o NCS a elegir

Verniciatura con prodotti ecologici idrosolubili (a base d'acqua)
Painting with water-soluble ecological products (water-based)
Peinture avec des produits écologiques solubles dans l'eau (à base d'eau)
Barnizado con productos ecológicos solubles en agua (a base de agua)

LACCATURA VELLUTO (a richiesta)
VELLUTO LACQUERING (on request)
LAQUÉ VELLUTO (sur demande)
LACA DE VELLUTO (bajo pedido)

*Laccatura VELLUTO non disponibile
VELLUTO lacquering not available
Laquè VELLUTO non disponibile
Laca de VELLUTO no disponible

Capitelli e Coprifili Armonia (a richiesta)

Armonia Capitals and architraves (on demand)

Capitales et architraves Armonia (sur demande)

Capitel y chambranas Armonia (previa solicitud)



CAPITELLO C1



COPRIFILI M50*



CAPITELLO C2



COPRIFILI LIBERTY



CAPITELLO C3

**coprifilo M50 non consente l'allineamento*

**architraves M50 does not allow alignment*

**architraves M50 ne permet pas l'alignement*

**chambranas M50 no permite la alineación*

Armonia Accessori

Accessories

Accessoires

Accesorios



CERNIERA ANUBA

Anuba hinges

Charnières anuba

Bisagra anuba



SERRATURA MAGNETICA FORNITA DI SERIE. FINITURA OTTONE A RICHIESTA

Magnetic lock supplied as standard. Ottone finish on demand

Serrure magnétique fournie de série. Finition ottone sur demande

Cerradura magnética suministrada de serie. Acabado en ottone bajo pedido

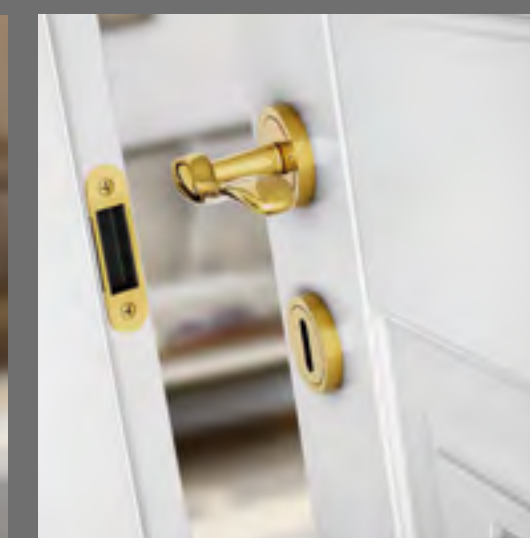

INCONTRO PER SERRATURA MAGNETICA FORNITA DI SERIE. FINITURA OTTONE A RICHIESTA

Hook lock for magnetic lock supplied as standard. Ottone finish on demand

Système de fermeture serrure magnétique fourni de série. Finition ottone sur demande

Ganchos para cerradura magnética suministrados de serie. Acabado en ottone bajo pedido

COLLEZIONE ESSENZIA

Essenzia Collection

Collection Essenzia

Colección Essenzia

ES508

ES510

ES512

B-System - telaio B-ZERO con coprifilo telescopico

B-System - B-ZERO frame with telescopic architrave

B-System - Cadre B-ZERO avec habillage télescopique

B-System - Marco B-Zero con chambranas telescópicas



Cerniere anuba e serratura magnetica

Anuba hinges and magnetic lock

Charnières anuba et serrure magnétique

Bisagra anuba y cerradura magnética



B System - Telaio B-uno, B-due con anta complanare Ko-zero rasoparete da un lato

*B-SYSTEM - support B-UNO and B-DUE frames with complanar door
and KO-ZERO flush on one side*

*B-SYSTEM - cadre de support B-UNO, B-DUE avec porte coplanaire
KO-ZERO à fleur de mur d'un côté*

*B-SYSTEM - marco B-UNO, B-DUE, con batiente
KO-ZERO alineado a la pared de un lado*



Cerniera registrabile a scomparsa e serratura magnetica

Hidden adjustable hinges and magnetic lock

Charnières réglables cachées et serrure magnétique

Bisagra ajustable oculta y cerradura magnética





ES508

*NOCE NAZIONALE
SISTEMA B-UNO*

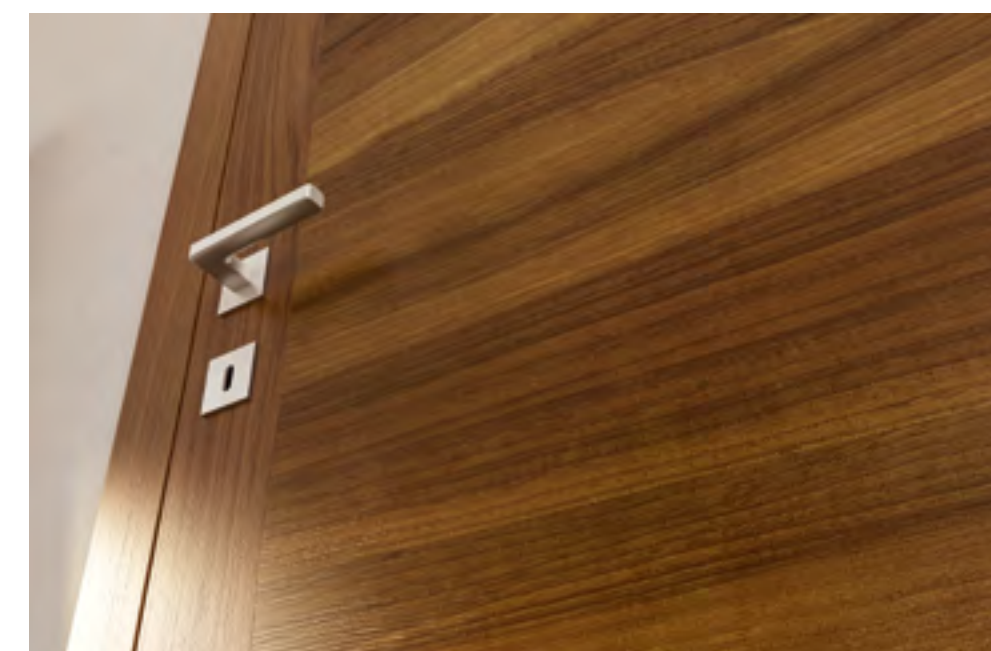



ES510

*ROVERE GRAFITE
SISTEMA KO-ZERO*

*SENZA FORO CHIAVE
(A RICHIESTA)*

*Without key hole (on request)
Sans trou de serrure (sur demande)
Sin agujero para llave (bajo pedido)*



ES510-V/City

*ROVERE GRAFITE
SISTEMA B-DUE
CRISTALLO NUVOLA GRIGIO*



ES512

*ROVERE FIORENTINO
SISTEMA B-ZERO*

Finiture Essenzia

Essenzia Finishes

Finitions Essenzia

Acabados Essenzia

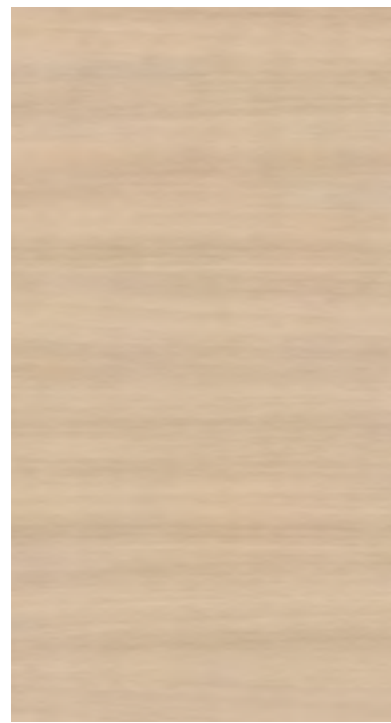

ROVERE SBIANCATO

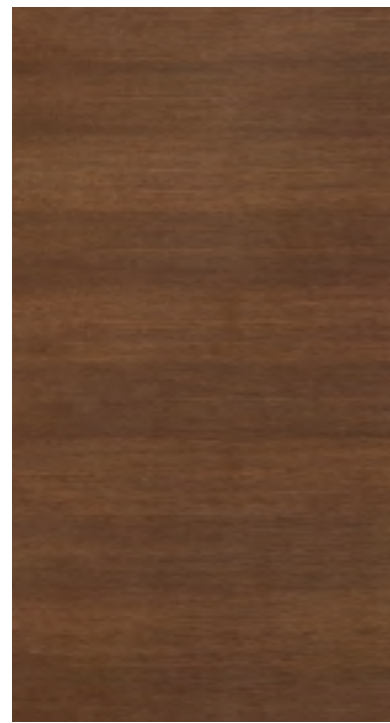

ROVERE GUINEA

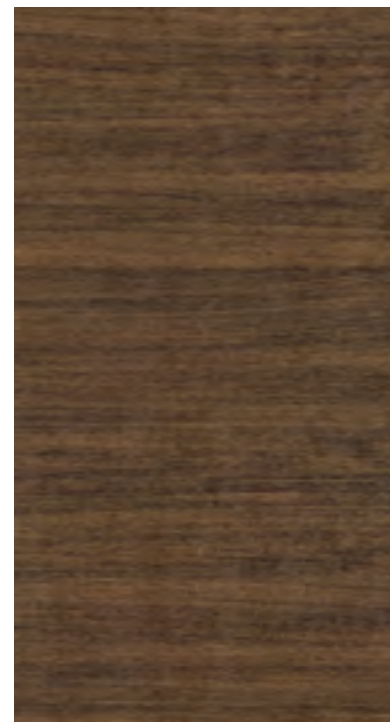

ROVERE NOCE

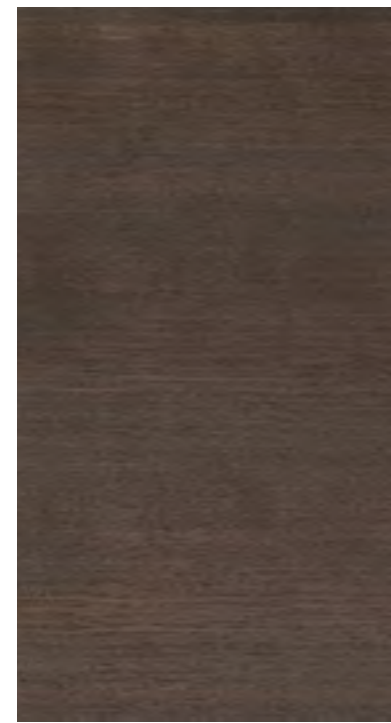

ROVERE GRIGIO

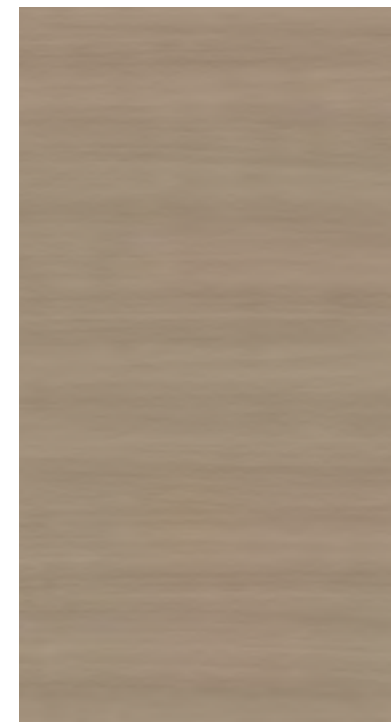

ROVERE GRAFITE

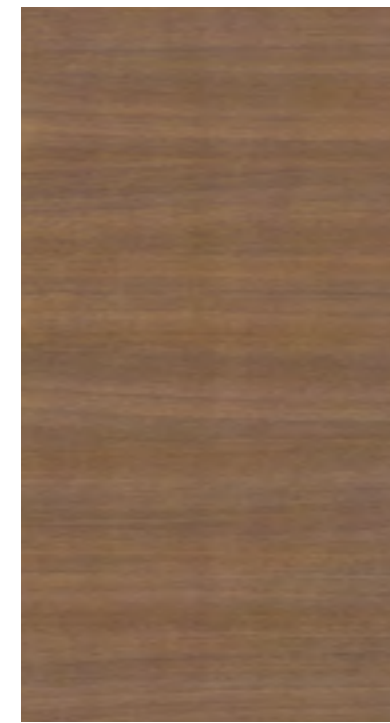

ROVERE FIORENTINO

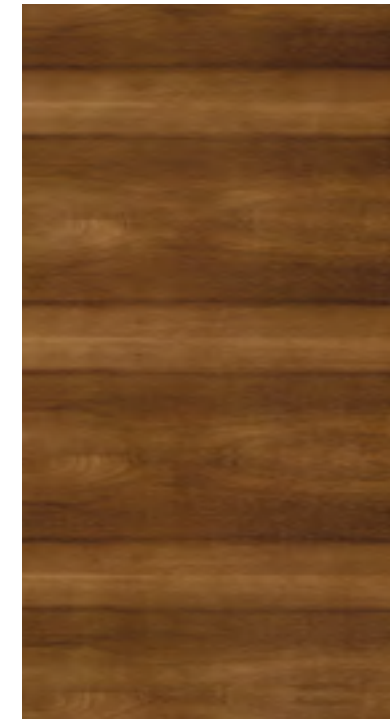

NOCE NAZIONALE

Essenzia Sistemi di Apertura

Opening systems

Systèmes d'ouverture

Sistemas de apertura

TELAIO IN ALLUMINIO

*Aluminum frame
Cadre en aluminium
Marco de aluminio*



SISTEMA B-UNO: COMPLANARE A SPINGERE

*B-UNO system: coplanar on push side
Système B-UNO: coplanaire à pousser
Sistema B-UNO: a empujar*

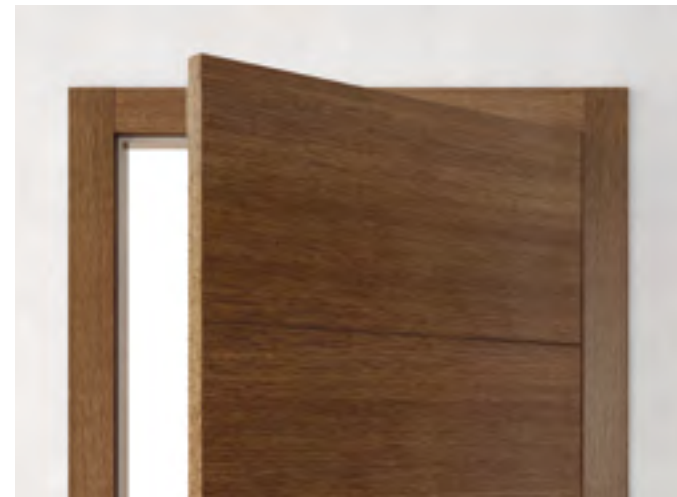

SISTEMA B-DUE: COMPLANARE A TIRARE

*B-DUE system: coplanar on pull side
Système B-DUE: coplanaire à tirer
Sistema B-DUE: a tirar*



SISTEMA KO-ZERO: COMPLANARE A SPINGERE

*KO-ZERO system: on push side
Système KO-ZERO: coplanaire à pousser
Sistema KO-ZERO: a empujar*

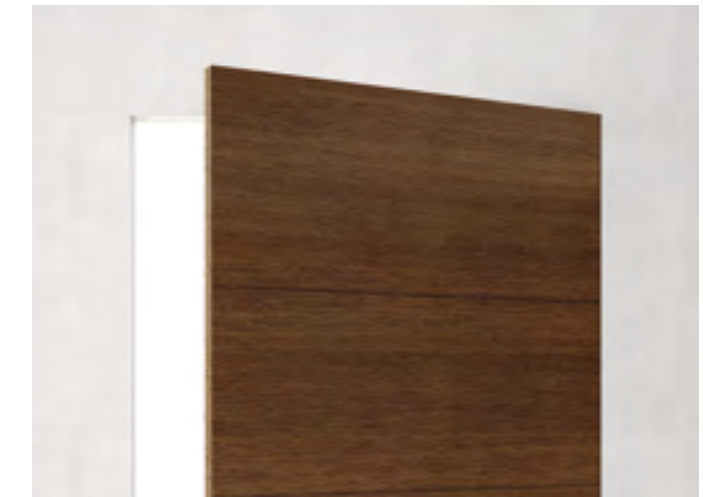

SISTEMA KO-ZERO: COMPLANARE A TIRARE

*KO-ZERO system: on pull side
Système KO-ZERO: coplanaire à tirer
Sistema KO-ZERO: a tirar*

Essenzia Accessori

Accessories

Accessoires

Accesorios

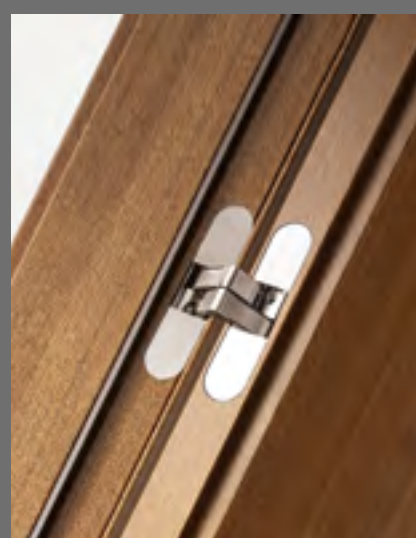

CERNIERA A SCOMPARSA
FORNITA DI SERIE

*Retractable hinge supplied
as standard*

*Charnières invisibles fournies
de série*

*Bisagra oculta suministrada
de serie*



CERNIERA ANUBA

Anuba hinges

Charnières Anuba

Bisagra Anuba



SERRATURA MAGNETICA
FORNITA DI SERIE

*Magnetic lock supplied
as standard*

*Serrure magnétique fournie
de série*

*Cerradura magnética suministrada
de serie*



INCONTRO PER
SERRATURA MAGNETICA
FORNITA DI SERIE

*Hook lock for magnetic lock
supplied as standard*

*Système de fermeture serrure
magnétique fourni de série*

*Ganchos para cerradura
magnética suministrados de serie*



KIT MANIGLIETTE TONDE CON SERRATURA
FORNITA DI SERIE PER SISTEMA SCORREVOLE
INTERNO MURO. SU RICHIESTA SERRATURA
PER SCORREVOLE ESTERNO MURO

*Round handle kit with lock supplied as standard for internal
sliding system. Lock on request for exterior wall sliding*

*Kit de poignées rondes avec serrure magnétique de série
pour système coulissant interne. Serrure sur demande pour
glissement de mur extérieur*

*Kit de manijas redondas suministrado de serie para sistemas
de puertas correderas interior pared. Disponible cerradura para
corredera exterior pared previa solicitud*



A RICHIESTA KIT MANIGLIETTE QUADRE
PER SISTEMA SCORREVOLE INTERNO
ED ESTERNO MURO. SU RICHIESTA SERRATURA
PER SCORREVOLE ESTERNO MURO

*On request square handle kit for interior and exterior wall sliding.
Lock on request for exterior wall sliding*

*Sur demande kit de poignées carrées pour coulissement
intérieur et mur extérieur. Verrou sur demande pour
glissement de mur extérieur*

*Kit de manijas cuadradas para sistemas de puertas correderas
interior y exterior pared. Disponible cerradura para corredera
exterior pared previa solicitud*

Vetri Essenza ES510-V/City

PARTICOLARE DELLA VERSIONE A VETRO

*Detail of the glass model
Détail de la version en verre
Detalle de la versión con vidrio*

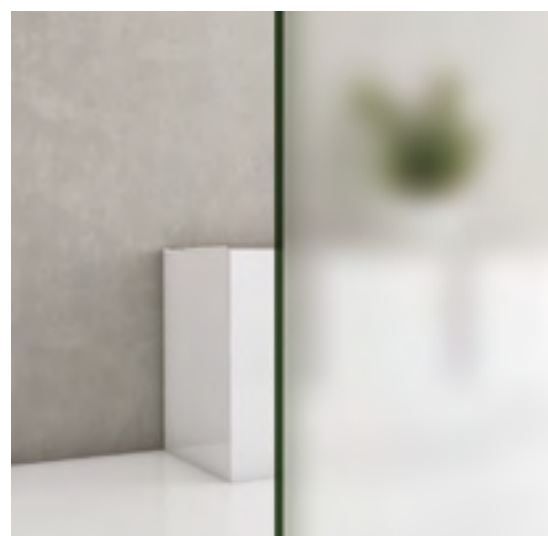
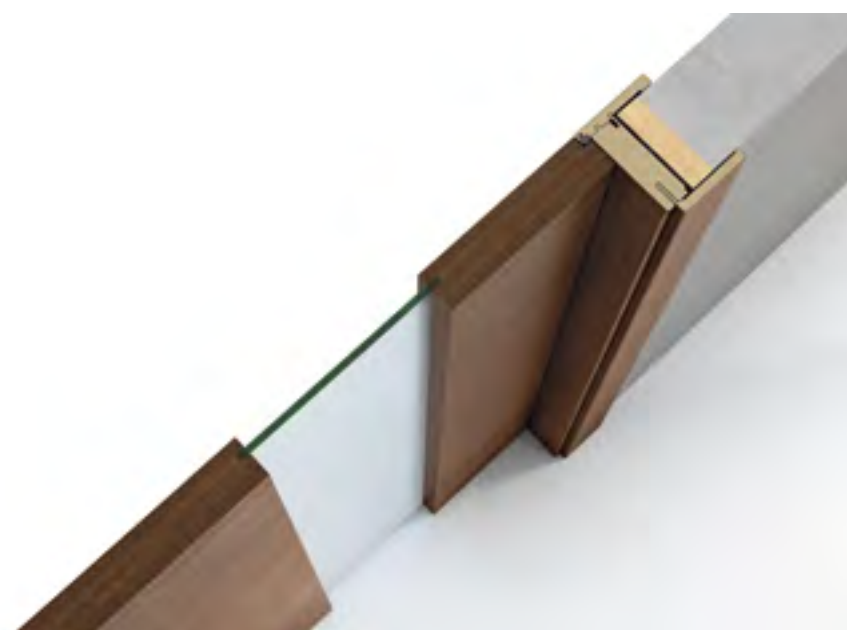

CRISTALLO NUVOLA BIANCO
(DI SERIE)

*White Nuvola Crystal (standard)
Cristal Nuvola Blanc (standard)
Cristal Nuvola Blanco (estándar)*

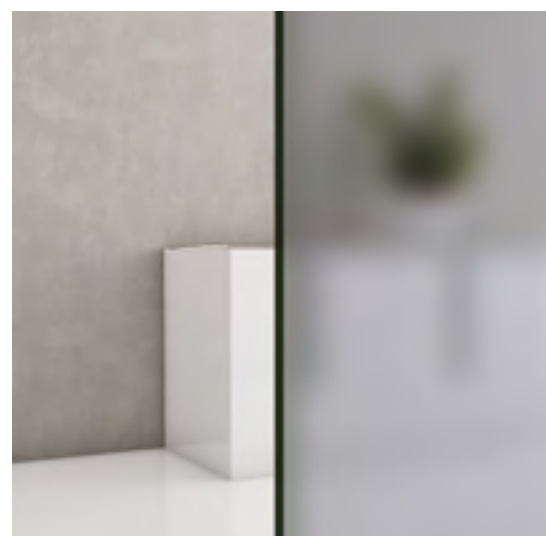

CRISTALLO NUVOLA GRIGIO
(SU RICHIESTA)

*Grey Nuvola Crystal (on demand)
Cristal Nuvola Gris (sur demand)
Cristal Nuvola Gris (previa solicitud)*



CRISTALLO NUVOLA BRONZO
(SU RICHIESTA)

*Bronze Nuvola Crystal (on demand)
Cristal Nuvola Bronze (sur demand)
Cristal Nuvola Bronce (previa solicitud)*

COLLEZIONE STILE

Stile Collection

Collection Stile

Colección Stile

ST601

ST607

ST608

ST609

ST614

B-System - telaio B-ZERO con coprifilo telescopico

B-System - B-ZERO frame with telescopic architrave

B-System - Cadre B-ZERO avec habillage télescopique

B-System - Marco B-Zero con chambranas telescópicas



Cerniere anuba e serratura magnetica

Anuba hinges and magnetic lock

Charnières anuba et serrure magnétique

Bisagra anuba y cerradura magnética





ST601
NOCE NAZIONALE



ST607/v

TANGANICA CILIEGIO
CRISTALLO SATINATO BIANCO
MODELLO CADY

ST607

TANGANICA CILIEGIO



ST608/v

TANGANICA
CRISTALLO SATINATO BIANCO
MODELLO FOGLIE





ST609/v

*NOCE NAZIONALE
CRISTALLO SATINATO BIANCO
MODELLO TULLE*



ST614
TANGANICA BLOND

Finiture Stile

Stile Finishes

Finitions Stile

Acabados Stile

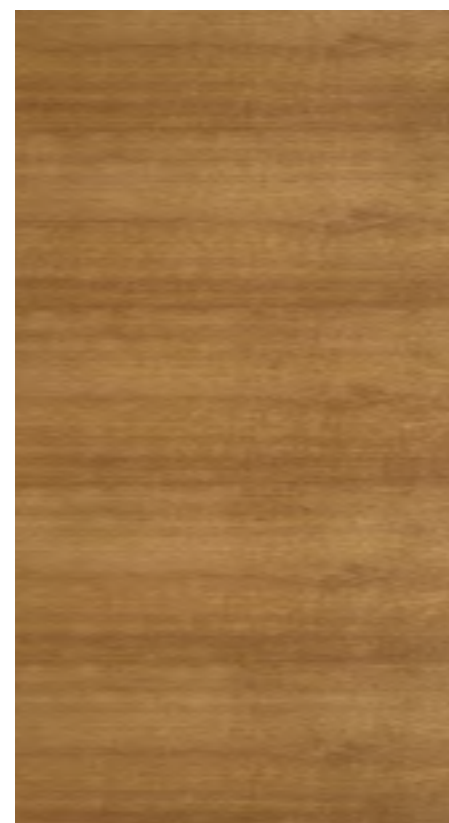

ROVERE

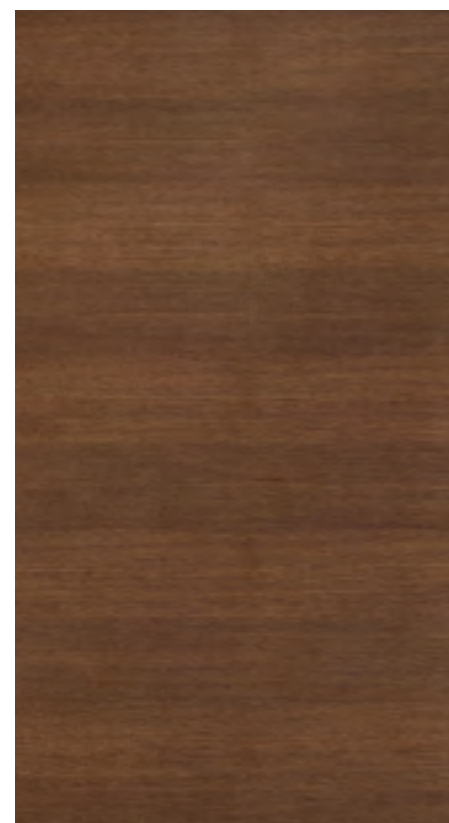

ROVERE GUINEA

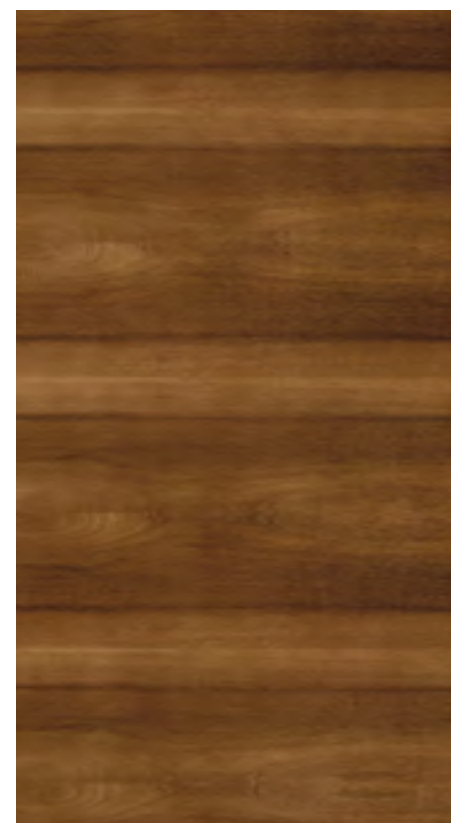

NOCE NAZIONALE

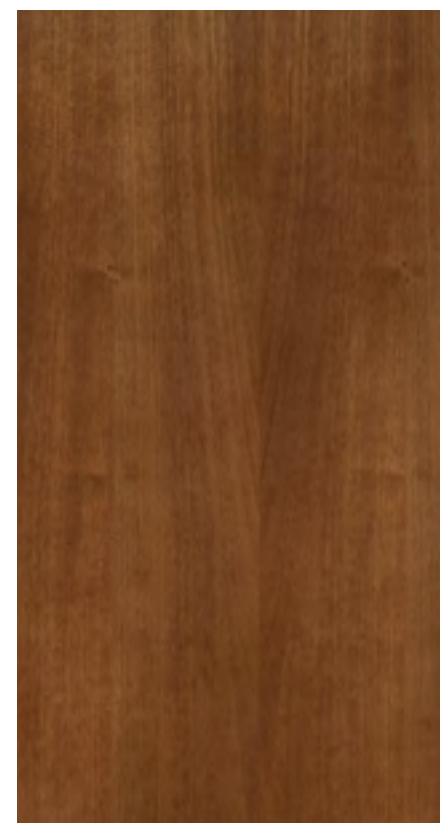

TANGANICA

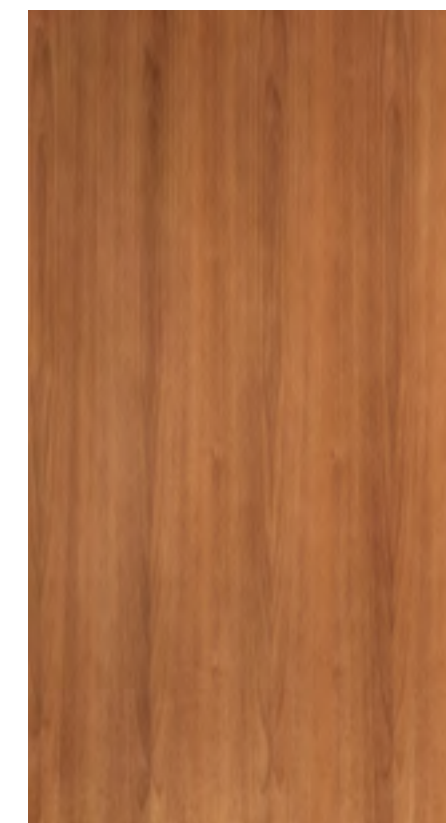

TANGANICA CILIEGIO

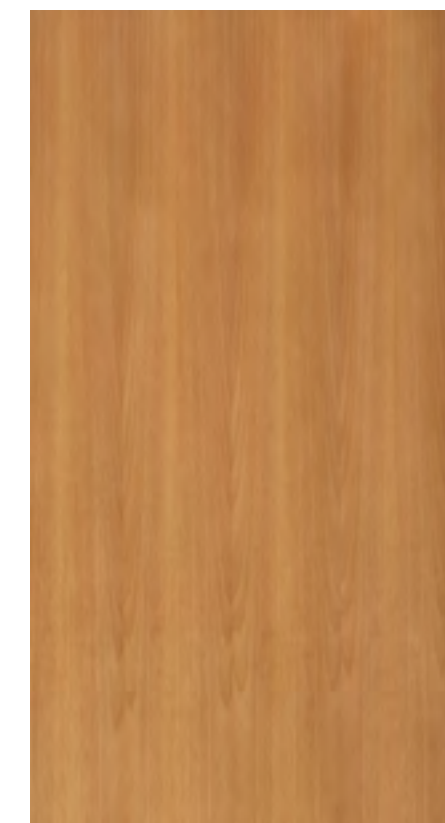

TANGANICA BLOND

Stile Sistemi di Apertura

Opening systems

Systèmes d'ouverture

Sistemas de apertura

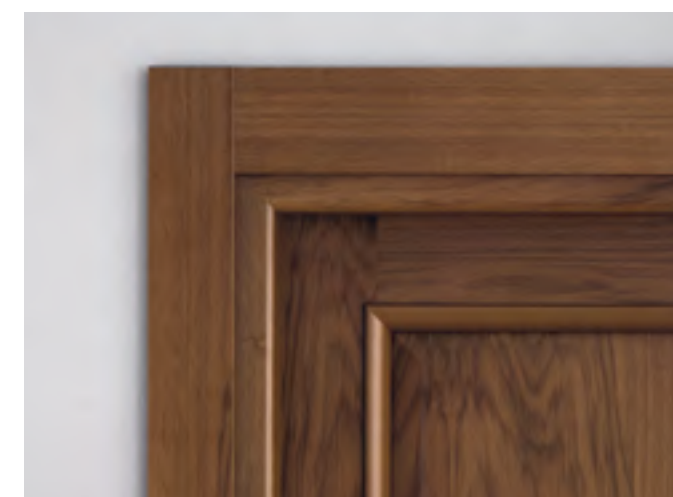

PARTICOLARE TELAIO B-ZERO CON
CERNIERA ANUBA

Detail support B-ZERO
Détail cadre de support B-ZERO
Detalle marco B-ZERO



PARTICOLARE TELAIO B-ZERO CON
CERNIERA ANUBA

Detail support B-ZERO frame with Anuba hinges
Détail cadre de support B-ZERO avec Charnières Anuba
Detalle marco B-ZERO con Bisagra Anuba

Stile Accessori

Accessories

Accessoires

Accesorios

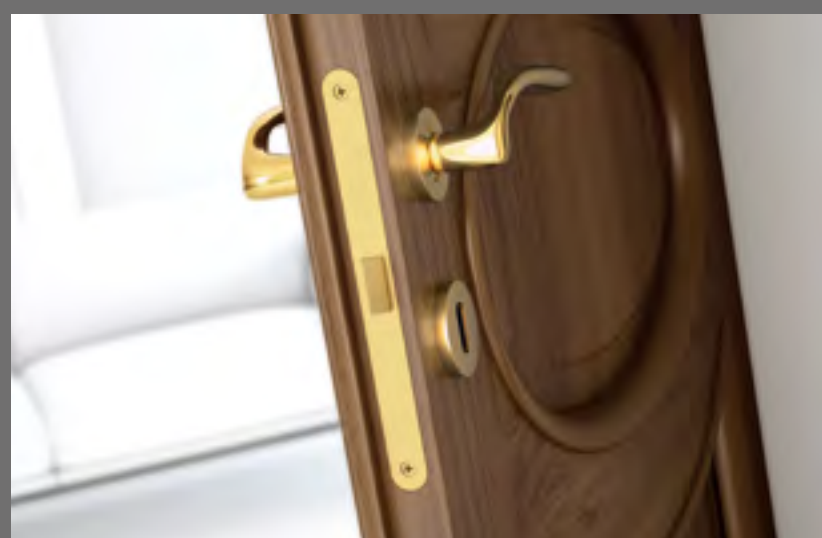

SERRATURA MAGNETICA FORNITA DI SERIE

Magnetic lock supplied as standard

Serrure magnétique fournie de série

Cerradura magnética suministrada de serie

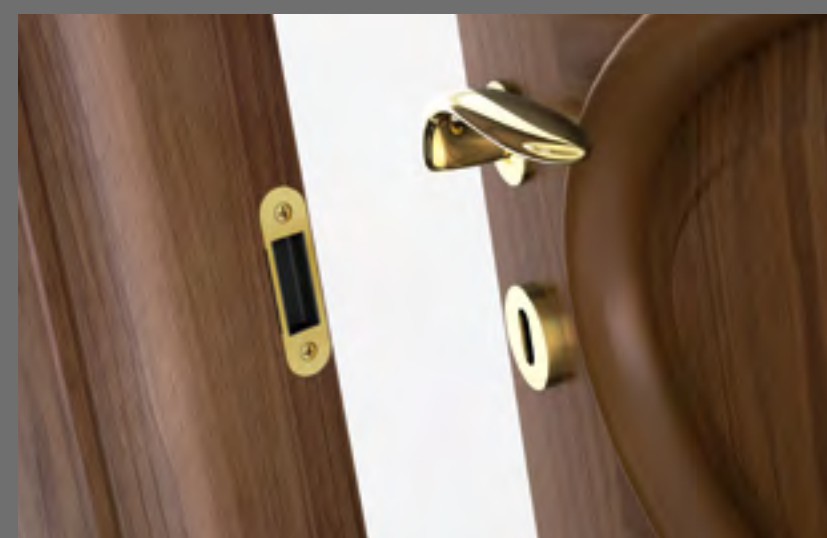

INCONTRO PER SERRATURA MAGNETICA FORNITA DI SERIE

Hook lock for magnetic lock supplied as standard

Système de fermeture serrure magnétique fourni de série

Ganchos para cerradura magnética suministrados de serie



KIT MANIGLIETTE TONDE CON SERRATURA FORNITA DI SERIE PER SISTEMA SCORREVOLE INTERNO MURO. SU RICHIESTA SERRATURA PER SCORREVOLE ESTERNO MURO

Round handle kit with lock supplied as standard for internal sliding system. Lock on request for exterior wall sliding

Kit de poignées rondes avec serrure magnétique de série pour système coulissant interne. Serrure sur demande pour glissement de mur extérieur

Kit de manijas redondas suministrado de serie para sistemas de puertas correderas interior pared. Disponible cerradura para corredera exterior pared previa solicitud



A RICHIESTA KIT MANIGLIETTE QUADRE PER SISTEMA SCORREVOLE INTERNO ED ESTERNO MURO. SU RICHIESTA SERRATURA PER SCORREVOLE ESTERNO MURO

On request square handle kit for interior and exterior wall sliding. Lock on request for exterior wall sliding

Sur demande kit de poignées carrées pour coulissement intérieur et mur extérieur. Verrou sur demande pour glissement de mur extérieur

Kit de manijas cuadradas para sistemas de puertas correderas interior y exterior pared. Disponible cerradura para corredera exterior pared previa solicitud

Metrica, Armonia, Stile

CRISTALLI TEMPERATI
DI SICUREZZA SATINATI
CON DECORO SABBBIATO

*Tempered safety glass doors, transparent base
or satin with sandblasted decorations*

Cristaux trempés sécurité fini avec décoration sablée

*Puertas de seguridad de cristal templado,
base transparente o satinada
con decoraciones esmeriladas*

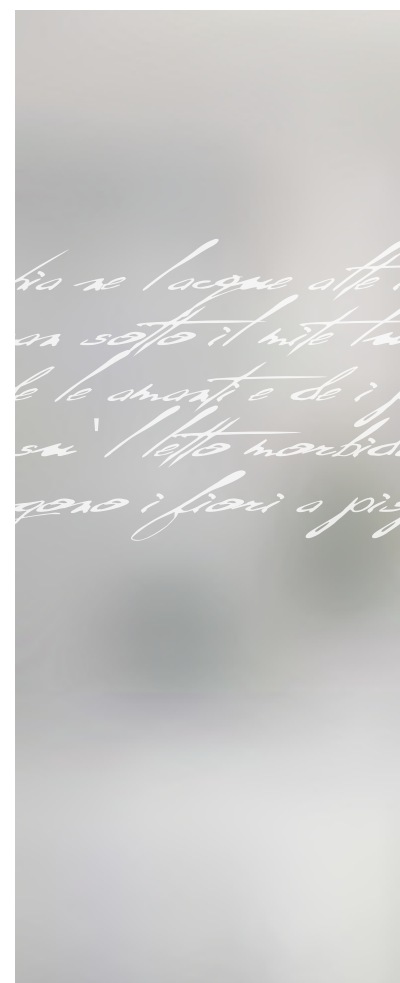

D'ANNUNZIO

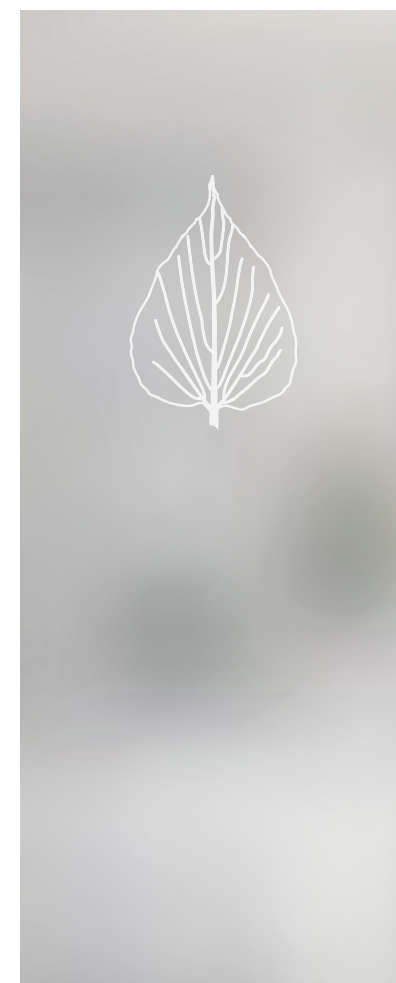

BOTANIA



FOGLIE



TESEO



SOFFIO



EPOQUE

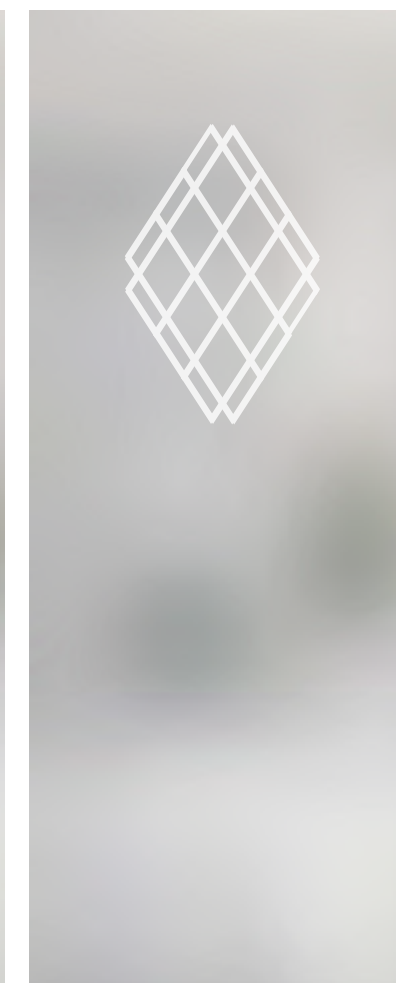

DIAMOND

*COLORI DISPONIBILI
ANCHE SU BASE*

*TRASPARENTE (a richiesta)
Available colours also available on
a transparent support (on demand)
Couleurs disponibles également
disponibles sur une base
transparente (sur demande)
Couleurs disponibles disponibles
con vidrio transparente también
(bajo pedido)*

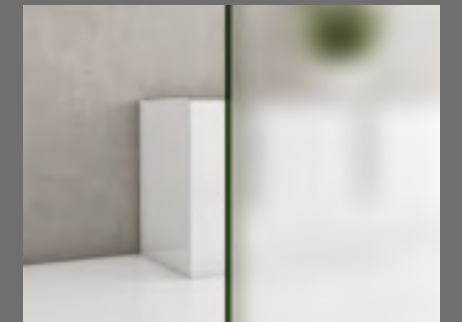

*CRISTALLO BASIC
SATINATO BIANCO (DI SERIE)
White Satin Basic Crystal (standard)
Cristal Basic De Satin Blanc (standard)
Cristal Basic Blanco Satinado (estándar)*



*CRISTALLO BASIC SATINATO
GRIGIO (SU RICHIESTA)
Grey Satin Basic Crystal (on demand)
Cristal Basic De Satin Gris (sur demand)
Cristal Basic Gris Satinado (previa solicitud)*

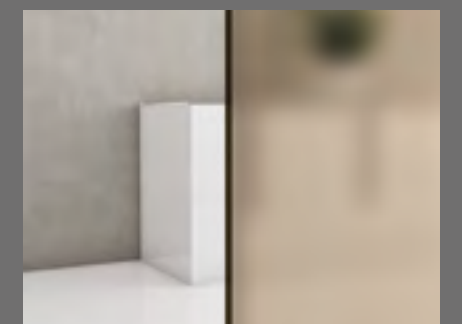

*CRISTALLO BASIC SATINATO
BRONZO (SU RICHIESTA)
Bronze Satin Basic Crystal (on demand)
Cristal Basic De Satin Bronze (sur demand)
Cristal Basic Bronce Satinado (previa solicitud)*

Metrica, Armonia, Stile

CRISTALLI SATINATI E SABBIATI

Sandblasted crystals

Cristaux sablés

Cristales esmerilados

DISPONIBILI ANCHE SU BASE TRASPARENTE

Also available on a transparent support

Également disponibles sur une base transparente

Disponibles con vidrio transparente también

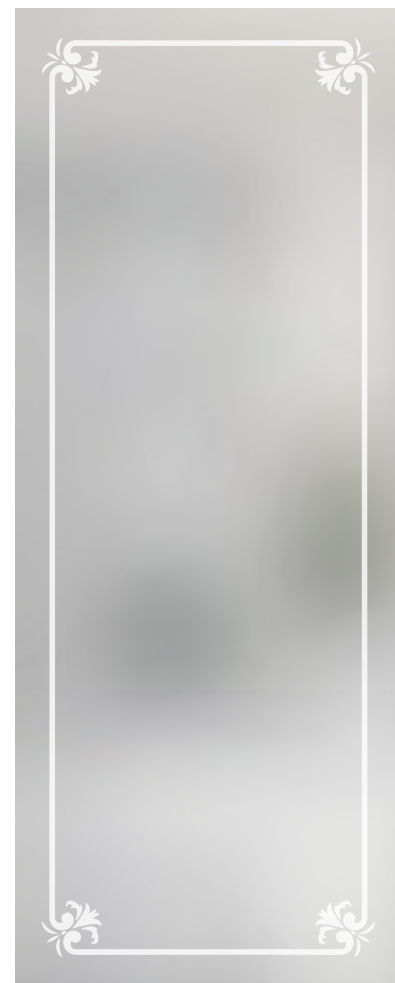

NACRÈ

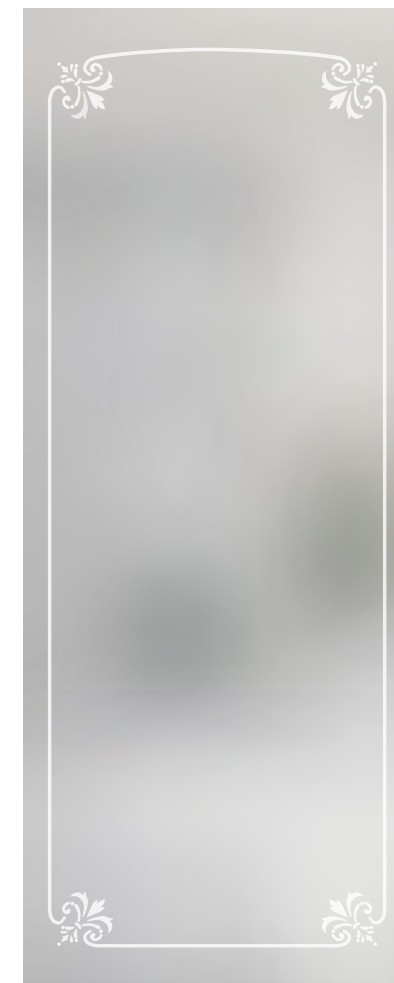

FENICE



CADY



TULLE

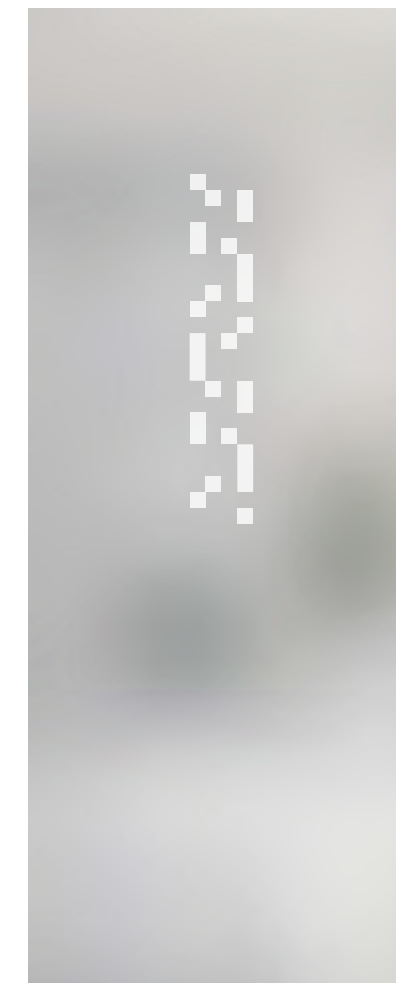

TETRIS



BUD



BUTTERFLY



KIARA

Driadi Sistemi di apertura

DRIADI opening systems

Systemes d'ouverture DRIADI

Sistemas de apertura DRIADI

Scorrevole Interno muro

*Inside wall sliding
Porte a galandage
Corredera interior pared*



Scorrevole Essential

Essential sliding
Porte coulissante Essential
Corredera Essential





Scorrevole Katana (non disponibile con serratura)

Katana sliding (not available with lock)
Porte coulissante Katana (non disponible avec serrure)
Corredera Katana (no disponible con cerradura)

FINITURA ARGENTO (DI SERIE)

Silver finish (standard)
Finition argentée (standard)
Acabado plata (estándar)

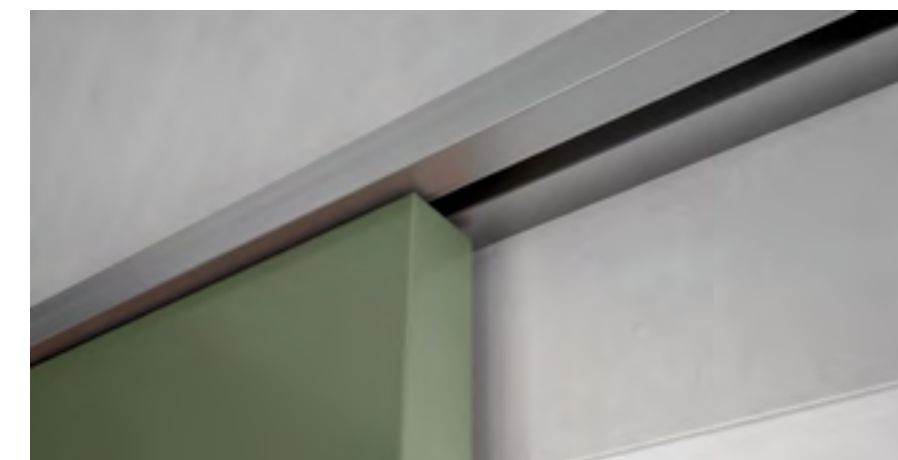

FINITURA BRONZO (SU RICHIESTA)

Bronze finish (on demand)
Finition bronze (sur demand)
Acabado bronce (previa solicitud)



FINITURA NERA (SU RICHIESTA)

Black finish (on demand)
Finition noire (sur demand)
Acabado negro (previa solicitud)





Scorrevole Inkasso (non disponibile con serratura)

Inkasso sliding (not available with lock)
Porte coulissante Inkasso (non disponible avec serrure)
Corredera Inkasso (no disponible con cerradura)



Scorrevole Global disponibile solo nella finitura argento)

*Global sliding,
Available only in argento finish
Porte coulissante Global,
Disponible uniquement en finition argento
Corredera Global,
Disponible solo en acabado argento*



Scorrevole Magicus (non disponibile con serratura)

Magicus sliding (not available with lock)
Porte coulissante Magicus (non disponible avec serrure)
Corredera Magicus (no disponible con cerradura)





Scorrevole Pratico

*Pratico sliding
Porte coulissante Pratico
Corredera Pratico*



Scorrevole Incontra (non disponibile con serratura)

Incontra sliding (not available with lock)
Porte coulissante Incontra (non disponible avec serrure)
Corredera Incontra (no disponible con cerradura)



Scorrevole Granluce

*Granluce Sliding
Porte Coulissante Granluce
Corredera Granluce*



Scorrevole con Mantovana

Sliding with pelmet
Porte coulissante avec cantonnière
Corredera con galería



Pieghevole a Libro

*Folding Door
Porte Pliante
Plegable de Libro*





Pieghevole Asimmetrica

*Asymmetrical Folding Door
Porte Pliante Asymétrique
Plegable Asimétrica*



Scorrevole Magicus per ante in vetro (non disponibile con serratura)

Magicus sliding for glass doors (not available with lock)
Porte Coulissante Magicus pour portes en verre (non disponible avec serrure)
Corredera Magicus para paneles de vidrio (no disponible con cerradura)





Scorrevole Odachi per ante in vetro (non disponibile con serratura)

Odachi sliding for glass doors (not available with lock)
Porte coulissante Odachi pour portes en verre (non disponible avec serrure)
Corredera Odachi para paneles de vidrio (no disponible con cerradura)



Scorrevole Inkasso per ante in vetro (non disponibile con serratura)

Inkasso sliding for glass doors (not available with lock)
Porte coulissante Inkasso pour portes en verre (non disponible avec serrure)
Corredera Inkasso para paneles de vidrio (no disponible con cerradura)

Maniglie per porte in legno

Handles

Poignées

Manijas



R 4 - CROMAT

Finiture disponibili: cromo, cromat

Finishes available: cromo, cromat

Finitions disponibles: cromo, cromat

Acabados disponibles: cromo, cromat



R 4S - CROMAT

Finiture disponibili: cromo, cromat

Finishes available: cromo, cromat

Finitions disponibles: cromo, cromat

Acabados disponibles: cromo, cromat



R 5 - NEROMAT

Finiture disponibili: cromo, cromat, neromat

Finishes available: cromo, cromat, neromat

Finitions disponibles: cromo, cromat, neromat

Acabados disponibles: cromo, cromat, neromat



R 5S - GAFITE MAT

Finiture disponibili: cromo, cromat, grafite, grafite mat, neromat

Finishes available: cromo, cromat, grafite, grafite mat, neromat

Finitions disponibles: cromo, cromat, grafite, grafite mat, neromat

Acabados disponibles: cromo, cromat, grafite, grafite mat, neromat

Maniglioni per porte in legno

Pulls

Barre de tirage

Manijones



R 1 - CROMAT

Finiture disponibili: cromo, cromat

Misura interasse: 300 mm

Finishes available: cromo/cromat

Interaxial measures: 300 mm

Finitions disponibles: cromo/cromat

Mesures interaxiales: 300 mm

Acabados disponibles: cromo/cromat

Medidas interaxiales: 300 mm



R 2 - CROMAT

Finiture disponibili: cromo, cromat, neromat

Misura interasse: 250 mm o 350 mm

Finishes available: cromo, cromat, neromat

Interaxial measures: 250 mm or 350 mm

Finitions disponibles: cromo, cromat, neromat

Mesures interaxiales: 250 mm ou 350 mm

Acabados disponibles: cromo, cromat, neromat

Medidas interaxiales: 250 mm o 350 mm



R 3 - CROMAT

Finiture disponibili: cromo, cromat, grafite, grafite mat, neromat

Misura interasse: 350 mm

Finishes available: cromo, cromat, grafite, grafite mat, neromat

Interaxial measures: 350 mm

Finitions disponibles: cromo, cromat, grafite, grafi mat, neromat

Mesures interaxiales: 350 mm

Acabados disponibles: cromo, cromat, grafite, grafi mat, neromat

Medidas interaxiales: 350 mm

Maniglie per porte in legno

Handles

Poignées

Manijas



ACADEMY SU ROSETTA

Finiture disponibili: argento, ottone, bronzo

Finishes available: argento, ottone, bronzo

Finitions disponibles: argento, ottone, bronzo

Acabados disponibles: argento, ottone, bronzo



FLORENCE SU ROSETTA

Finiture disponibili: ottone, bronzo, nichel

Finishes available: ottone, bronzo, nichel

Finitions disponibles: ottone, bronzo, nichel

Acabados disponibles: ottone, bronzo, nichel



ACADEMY CON PLACCA

Finiture disponibili: argento, ottone, bronzo

Finishes available: argento, ottone, bronzo

Finitions disponibles: argento, ottone, bronzo

Acabados disponibles: argento, ottone, bronzo



FLORENCE CON PLACCA

Finiture disponibili: ottone, bronzo

Finishes available: ottone, bronzo

Finitions disponibles: ottone, bronzo

Acabados disponibles: ottone, bronzo



LILIA SU ROSETTA

Finiture disponibili: cromo, ottone, bronzo

Finishes available: cromo, ottone, bronzo

Finitions disponibles: cromo, ottone, bronzo

Acabados disponibles: cromo, ottone, bronzo



PLATINO SU ROSETTA

Finiture disponibili: ottone, bronzo, nichel

Finishes available: ottone, bronzo, nichel

Finitions disponibles: ottone, bronzo, nichel

Acabados disponibles: ottone, bronzo, nichel

Maniglioni per porte in legno

Pulls

Barre de tirage

Manijones



LILIA CON PLACCA

Finiture disponibili: cromo, ottone, bronzo

Finishes available: cromo, ottone, bronzo

Finitions disponibles: cromo, ottone, bronzo

Acabados disponibles: cromo, ottone, bronzo



PLATINO CON PLACCA

Finiture disponibili: ottone, bronzo, nichel

Finishes available: ottone, bronzo, nichel

Finitions disponibles: ottone, bronzo, nichel

Acabados disponibles: ottone, bronzo, nichel

Maniglie per porte in legno

Handles

Poignées

Manijas



VENICE SU ROSETTA

Finiture disponibili: ottone, bronzo

Finishes available: cromo, ottone, bronzo

Finitions disponibles: cromo, ottone, bronzo

Acabados disponibles: cromo, ottone, bronzo



CENERENTOLA SU ROSETTA

Finiture disponibili: orsatin, bronzop, light black, rame

Finishes available: orsatin, bronzop, light black, rame

Finitions disponibles: orsatin, bronzop, light black, rame

Acabados disponibles: orsatin, bronzop, light black, rame



VENICE MANIGLIONE

Finiture disponibili: ottone, bronzo

Finishes available: ottone, bronzo

Finitions disponibles: ottone, bronzo

Acabados disponibles: ottone, bronzo



CENERENTOLA MANIGLIONE

Finiture disponibili: orsatin, bronzop, light black, rame

Finishes available: orsatin, bronzop, light black, rame

Finitions disponibles: orsatin, bronzop, light black, rame

Acabados disponibles: orsatin, bronzop, light black, rame



POP SU ROSETTA

Finiture disponibili: black, blu, purple, red, white, yellow, mat blck, mat blue, mat green, mat white

Finishes available: black, blu, purple, red, white, yellow, mat blck, mat blue, mat green, mat white

Finitions disponibles: black, blu, purple, red, white, yellow, mat blck, mat blue, mat green, mat white

Acabados disponibles: black, blu, purple, red, white, yellow, mat blck, mat blue, mat green, mat white

Maniglioni per porte in legno

Pulls

Barre de tirage

Manijones



POP CON PLACCA

Finiture disponibili: black, blu, purple, red, white, yellow, mat blck, mat blue, mat green, mat white

Finishes available: black, blu, purple, red, white, yellow, mat blck, mat blue, mat green, mat white

Finitions disponibles: black, blu, purple, red, white, yellow, mat blck, mat blue, mat green, mat white

Acabados disponibles: black, blu, purple, red, white, yellow, mat blck, mat blue, mat green, mat white

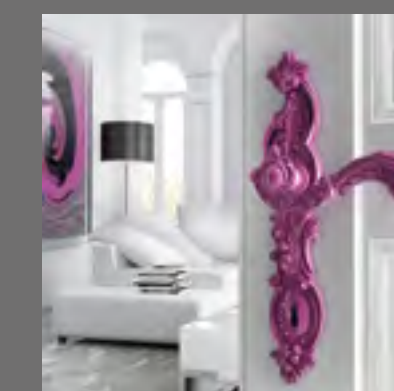

Maniglie per porte in vetro

Handles

Poignées

Manijas

Maniglioni per porte in vetro

Pulls

Barre de tirage

Manijones

PORTA A BATTENTE

For hinged doors
Pour porte battante
Para puertas batientes



VITRA
modello solo maniglia (di serie)

model with handle only (on demand)
version avec poignée (sur demand)
versión con manija (previa solicitud)



VITRA N
modello con nottolino (a richiesta)

model with door latch (on demand)
modèle avec cliquet (sur demande)
versión con pestillo (previa solicitud)



VITRA C
modello con cilindro (a richiesta)

model with barrel (on demand)
modèle avec cylindre (sur demande)
versión con cilindro o bombín (previa solicitud)

PORTA A SCORREVOLE

For sliding doors
Pour porte coulissante
Para puertas correderas



MANIGLIETTA ADESIVA (di serie)

Self-adhesive door handle (standard)
Poignées adhésives (de série)
Manija adhesiva (estándar)



NICCHIA PER SCORREVOLE
modello NC-22 (a richiesta)

Recessed sliding doors NC-22 model (on demand)
Recoin pour porte coulissante model NC-22 (sur demand)
Nicho para correderas modelo NC-22 (previa solicitud)



NICCHIA PER SCORREVOLE
modello NC-24 (a richiesta)

Recessed sliding doors NC-24 model (on demand)
Recoin pour porte coulissante model NC-24 (sur demand)
Nicho para correderas modelo NC-24 (previa solicitud)



RING

Finiture disponibili: acciaio inox satinato
dimensioni: 300 mm / 1200 mm x Ø 20 mm o 25 mm

Finiture disponibili: acciaio inox lucido
dimensioni: 300 mm / 700 mm x Ø 20 mm

Finishes available: acciaio inox satinato
sizes: 300 mm / 1200 mm x Ø 20 mm o 25 mm

Finitions disponibles: acciaio inox satinato
mesures: 300 mm/1200 mm x Ø 20 mm o 25 mm

Acabados disponibles: acciaio inox satinato
medidas: 300 mm / 1200 mm x Ø 20 mm o 25 mm



ERGO

Finiture disponibili: acciaio inox satinato
dimensioni: 300 mm x Ø 25 mm

Finishes available: acciaio inox satinato
sizes: 300 mm x Ø 25 mm

Finitions disponibles: acciaio inox satinato
mesures: 300 mm x Ø 25 mm

Acabados disponibles: acciaio inox satinato
medidas: 300 mm x Ø 25 mm

Finiture Ferramenta Driadi

Driadi hardware fittings

Quincaillerie Driadi

Acabados de hardware Driadi

CERNIERA A SCOMPARSA PER MODELLI

KUADRA, SOFT, INCONTRI, ESSENZIA

Hidden hinges for collections Kuadra, Soft, Incontri, Essenzia
Charnières cachées pour les collections Kuadra, Soft, Incontri, Essenzia
Bisagra oculta para colecciones Kuadra, Soft, Incontri, Essenzia



*CROMO
SATINATO
(di serie)*

OTTONE

BRONZATO

NERO

BIANCO

CERNIERA PER ANTE IN VETRO

Hinge for glass doors
Charnière pour portes en verre
Bisagra para paneles de vidrio

CERNIERA IN ABBINAMENTO

ALLA MANIGLIA VITRA

Hinge in combination with the Vitra handle
Charnière en combinaison avec la poignée Vitra
Bisagra combinada con la manija Vitra



SERRATURA

Lock
Serrure
Cerradura



*CROMO
SATINATO
(di serie)*

OTTONE

BRONZATO

NERO

BIANCO

Caratteristiche Tecniche Sistema B-ZERO (collezione Metrica, Armonia, Essenza, Stile, Light)

Technical sheet B-ZERO system (Metrica, Armonia, Essenza, Stile, Light collections)
Caractéristiques techniques système B-ZERO (colletion Metrica, Armonia, Essenza, Stile, Light)
Características técnicas sistema B-ZERO (colección Metrica, Armonia, Essenza, Stile, Light)

1. 3 CERNIERE ANUBA
2. SERRATURA MAGNETICA
3. SPESSORE ANTA 44 MM
4. BORDATURA SU 3 LATI

1. 3 Anuba hinges
2. Magnetic Lock
3. Door thickness 44 mm bordered
4. Bordered on 3 sides

1. 3 charnières Anuba
2. Serrure magnétique
3. épaisseur de la porte 44 mm
4. Bordures sur 3 côtés

1. 3 Bisagras Anuba
2. Cerradura magnética
3. Espesor hoja 44 mm
4. Borde de 3 lados

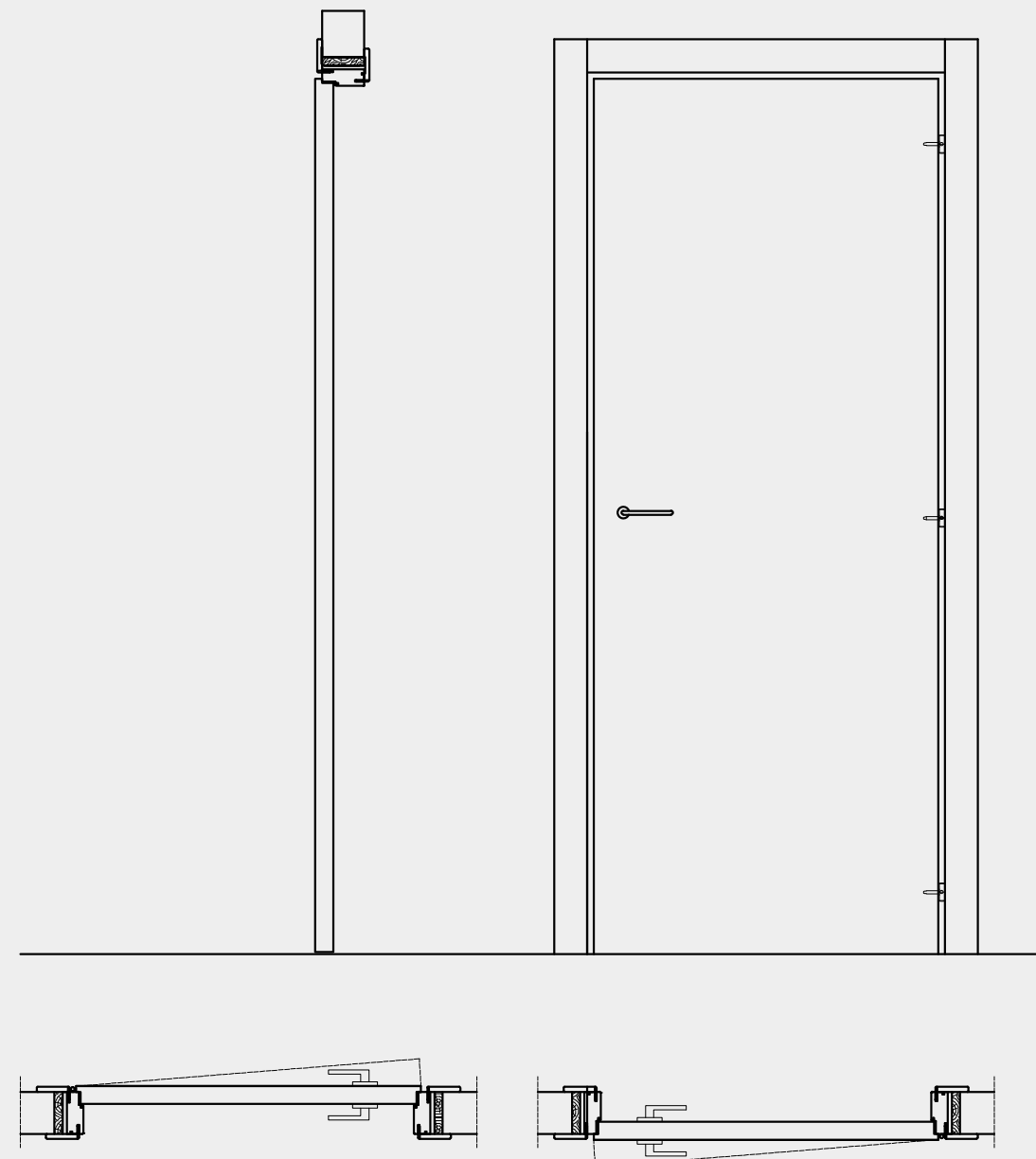

Misure ingombri per porta battente Sistema B-ZERO (collezione Metrica, Armonia, Essenza, Stile, Light, Ante in vetro)

*Overall dimensions B-ZERO system for leaf door
(Metrica, Armonia, Essenza, Stile, Light, Glass door collections)*
*Dimensions hors tout système B-ZERO pour porte battante
(collection Metrica, Armonia, Essenza, Stile, Light, Portes vitrées)*

*Medidas para la puerta batiente Sistema B-ZERO
(colección Metrica, Armonia, Essenza, Stile, Light, Puertas de cristal)*

MN	FM	L	LTS	LTT	H	HTS	HTT
60x210	70x215	60	78	83	210	219	221
70x210	80x215	70	88	93	210	219	221
80x210	90x215	80	98	103	210	219	221
90x210	100x215	90	108	113	210	219	221

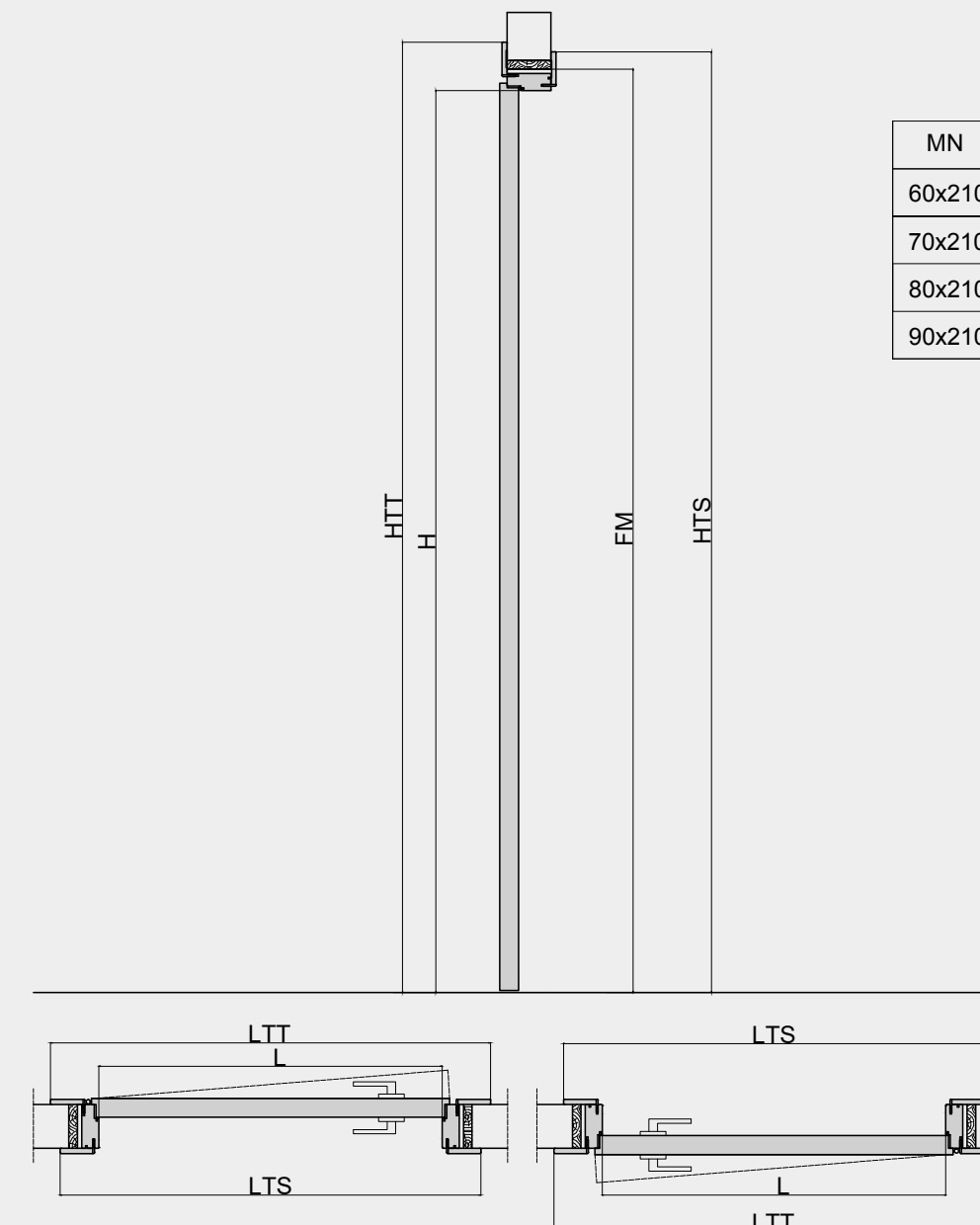

Particolari tecnici Sistema B-ZERO (collezione Metrica, Armonia, Essenza, Stile, Light, Ante in vetro)

*Technical details B-ZERO system
(Metrica, Armonia, Essenza, Stile, Light, Glass door collections)*

*Détails techniques système B-ZERO
(collection Metrica, Armonia, Essenza, Stile, Light, Portes vitrées)*

*Detalles técnicos sistema B-ZERO
(colección Metrica, Armonia, Essenza, Stile, Light, Puertas de cristal)*



*DETTAGLIO DELL'ANTA BORDATA SU TRE LATI.
SEZIONE DEL TELAIO STANDARD DA 10.2 CM
PER MURO DA 10 A 11.5 CM*

*Detail of the door bordered on three sides.
Standard frame section of 10.2 cm
for walls from 10 to 11.5 cm*

*Détail de la porte bordée sur trois côtés.
Coupe du cadre standard de 10.2 cm
pour un mur de 10 à 11.5 cm*

*Detalle de la hoja bordada de tres lados.
Sección estándar del marco de 10.2 cm
para pared de 10 a 11.5 cm*

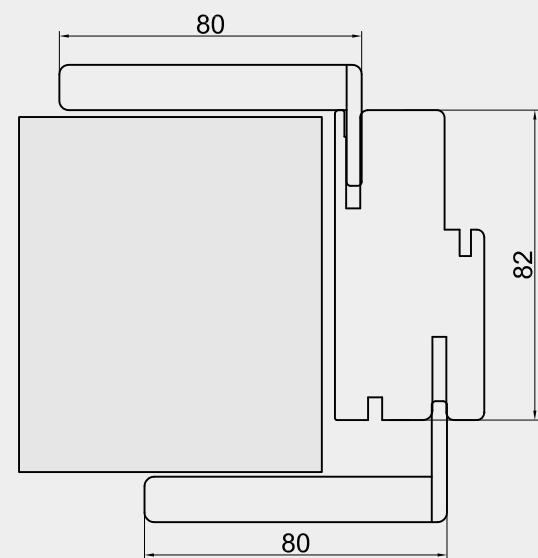

Per muro spesso da 8 a 9,5 cm
*For thickness from 8 to 9.5 cm
Elargissement pour épaisseur de mur de 8 à 9.5 cm
Expansión pared de 8 a 9.5 cm*

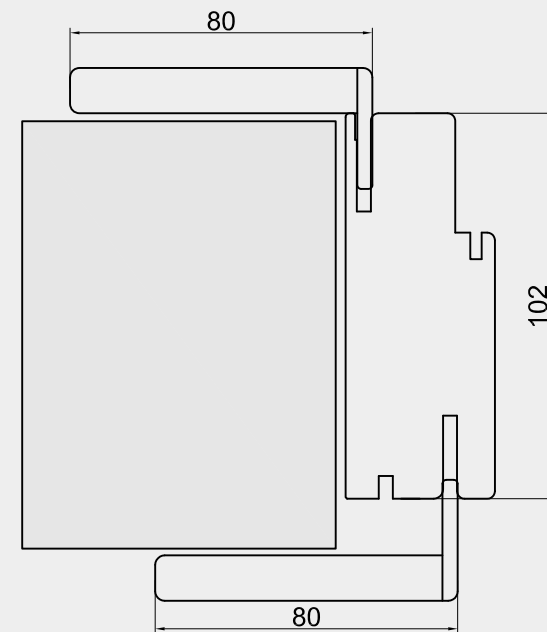

Per muro spesso da 10 a 11.5 cm
*For thickness from 10 to 11.5 cm
Elargissement pour épaisseur de mur de 10 à 11.5 cm
Expansión pared de 10 a 11.5 cm*

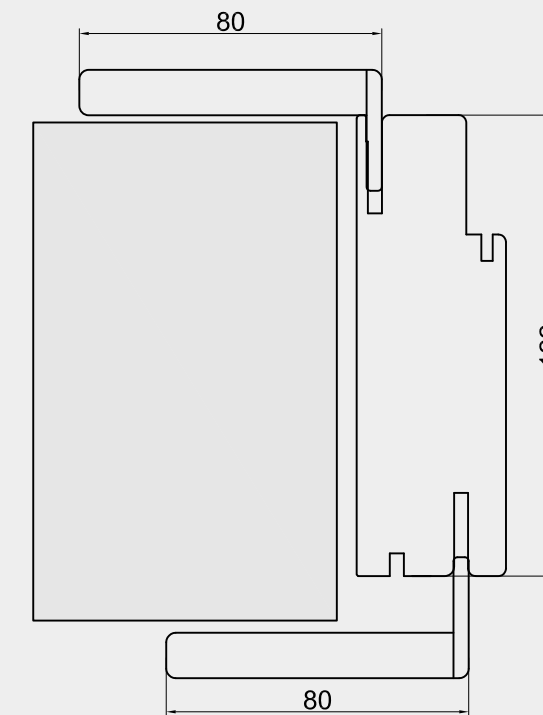

Per muro spesso da 12 a 13.5 cm
*For thickness from 12 to 13.5 cm
Elargissement pour épaisseur de mur de 12 à 13.5 cm
Expansión pared de 12 a 13.5 cm*

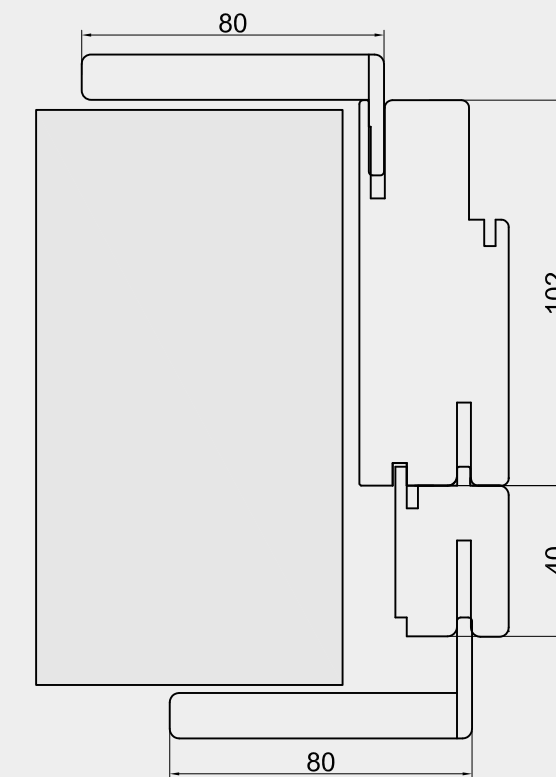

Allargamento per muro spesso da 14 a 15.5 cm
*Footing for thickness from 14 to 15.5 cm
Elargissement pour épaisseur de mur de 14 à 15.5 cm
Expansión pared de 14 a 15.5 cm*

Particolari tecnici Sistema B-ZERO (collezione Metrica, Armonia, Essenza, Stile, Light, Ante in vetro)

*Technical details B-ZERO system
(Metrica, Armonia, Essenza, Stile, Light, Glass door collections)*

*Détails techniques système B-ZERO
(collection Metrica, Armonia, Essenza, Stile, Light, Portes vitrées)*

*Detalles técnicos sistema B-ZERO
(colección Metrica, Armonia, Essenza, Stile, Light, Puertas de cristal)*



*DETTAGLIO DELL'ANTA IN VETRO.
SEZIONE DEL TELAIO STANDARD DA 10.2 CM
PER MURO DA 10 A 11.5 CM*

*Detail of the glass door.
Standard frame section of 10.2 cm
for walls from 10 to 11.5 cm*

*Détail de la porte vitrée.
Coupe du cadre standard de 10.2 cm
pour un mur de 10 à 11.5 cm*

*Detalle de la puerta de cristal.
Sección estandar del marco de 10.2 cm
para pared de 10 a 11.5 cm*

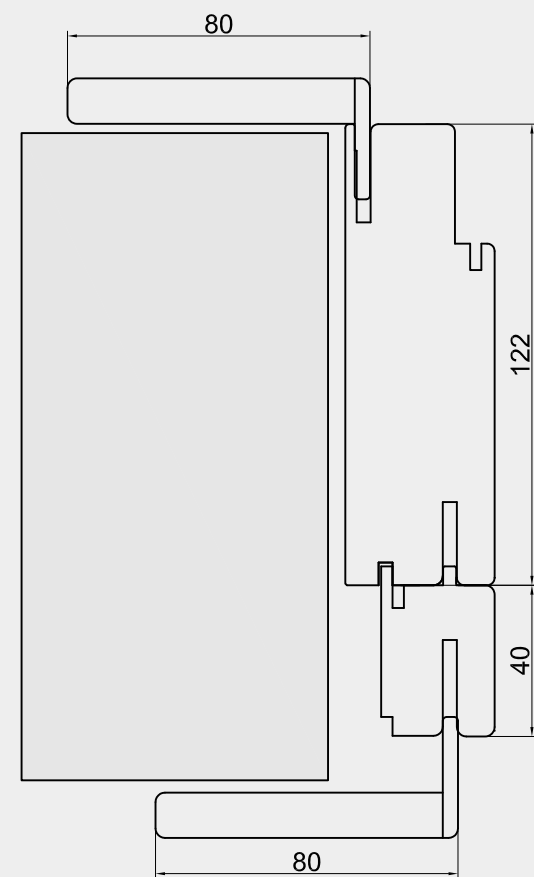

Allargamento per muro spesso da 16 a 17.5 cm
Footing for thickness from 16 to 17.5 cm
Elargissement pour épaisseur de mur de 16 à 17.5 cm
Expansión pared de 16 a 17.5 cm

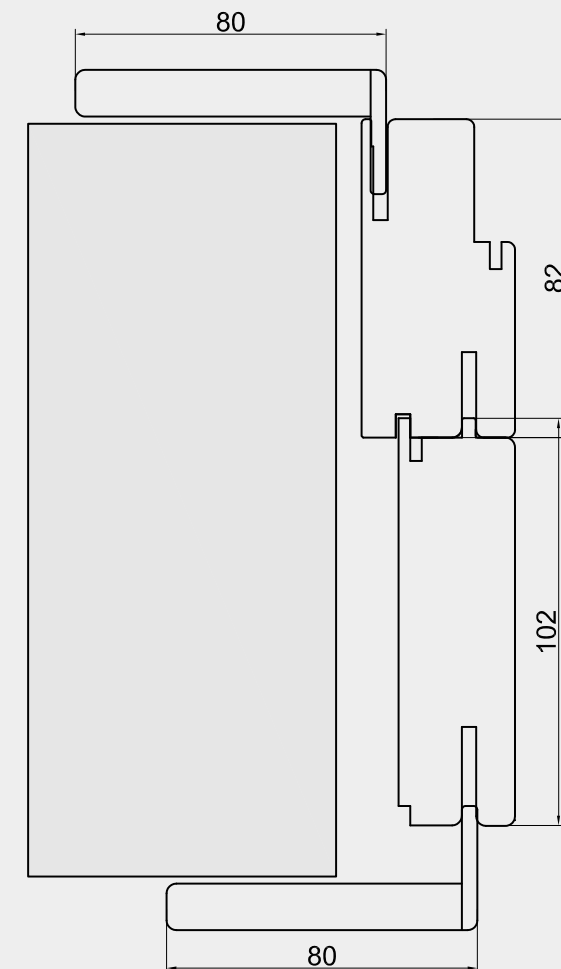

Allargamento per muro spesso da 18 a 19.5 cm
Footing for thickness from 18 to 19.5 cm
Elargissement pour épaisseur de mur de 18 à 19.5 cm
Expansión pared de 18 a 19.5 cm

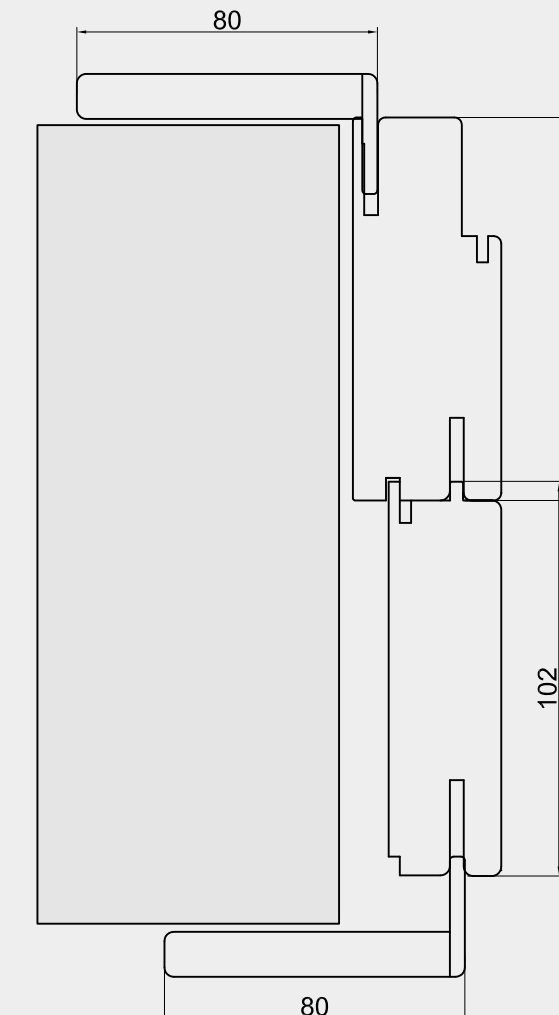

Allargamento per muro spesso da 20 a 21.5 cm
Footing for thickness from 20 to 21.5 cm
Elargissement pour épaisseur de mur de 20 à 21.5 cm
Expansión pared de 20 a 21.5 cm

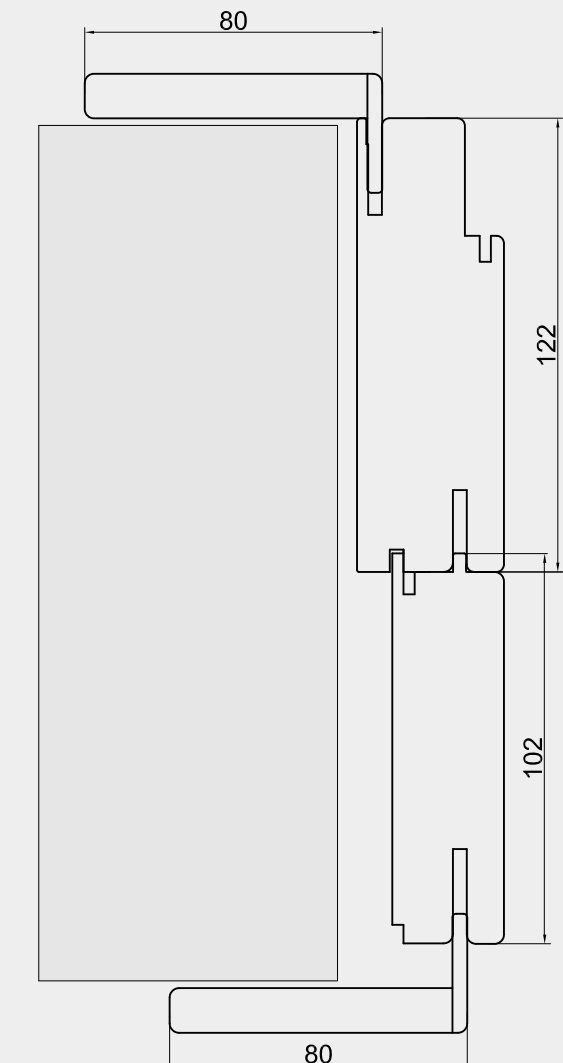

Allargamento per muro spesso da 22 a 23.5 cm
Footing for thickness from 22 to 23.5 cm
Elargissement pour épaisseur de mur de 22 à 23.5 cm
Expansión pared de 22 a 23.5 cm

Caratteristiche tecniche Sistema B-UNO (collezione Kuadra, Soft, Incontri, Essenzia)

Technical sheet B-UNO system (Kuadra, Soft ,Incontri and Essenzia collection)

Caractéristiques techniques système B-UNO (colletion Kuadra, Soft , Incontri et Essenzia)

Características técnicas sistema B-UNO (colección Kuadra, Soft, Incontri y Essenzia)

1. 3 CERNIERE A SCOMPARSA
2. SERRATURA MAGNETICA
3. COMPLANARE NEL LATO A SPINGERE
4. SPESSORE ANTA 44 MM
5. BORDATURA SU 3 LATI

1. 3 hidden hinges
2. Magnetic lock
3. Complanar on the push side
4. Thickness of the door 44 mm
5. Edge banding on 3 sides

1. 3 charnières dissimulées
2. Serrure magnétique
3. Partie affleurante du côté a pousser
4. Epaisseur de la porte 44 mm
5. Bordures sur 3 côtés

1. 3 bisagras ocultas
2. Cerradura magnética
3. Enrasada con la pared (lado a empujar)
4. Espesor hoja 44 mm
5. Borde de 3 lados

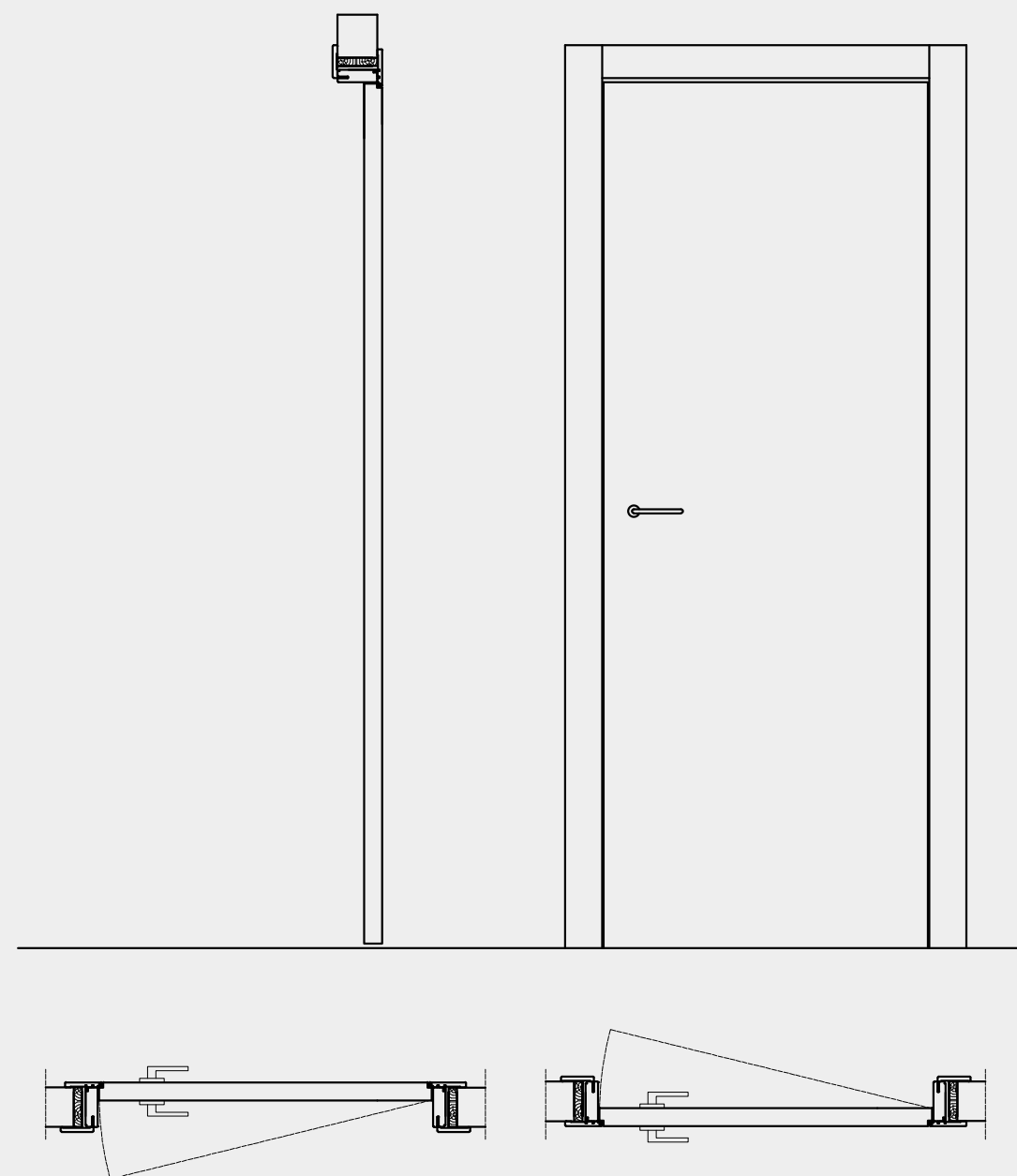

Misure ingombri per porta battente Sistema B-UNO (collezione Kuadra, Soft, Incontri, Essenzia)

*Overall dimensions for leaf door B-UNO system
(Kuadra, Soft, Incontri and Essenzia collection)*

*Dimensions hors tout pour porte battante système B-UNO
(colletion Kuadra, Soft, Incontri et Essenzia)*

*Medidas para la puerta batiente sistema B-UNO
(colección Kuadra, Soft, Incontri y Essenzia)*

MN	FM	L	LTS	LTT	H	HTS	HTT
60x210	70x215	60	78	80	210	219	220
70x210	80x215	70	88	90	210	219	220
80x210	90x215	80	98	100	210	219	220
90x210	100x215	90	108	110	210	219	220

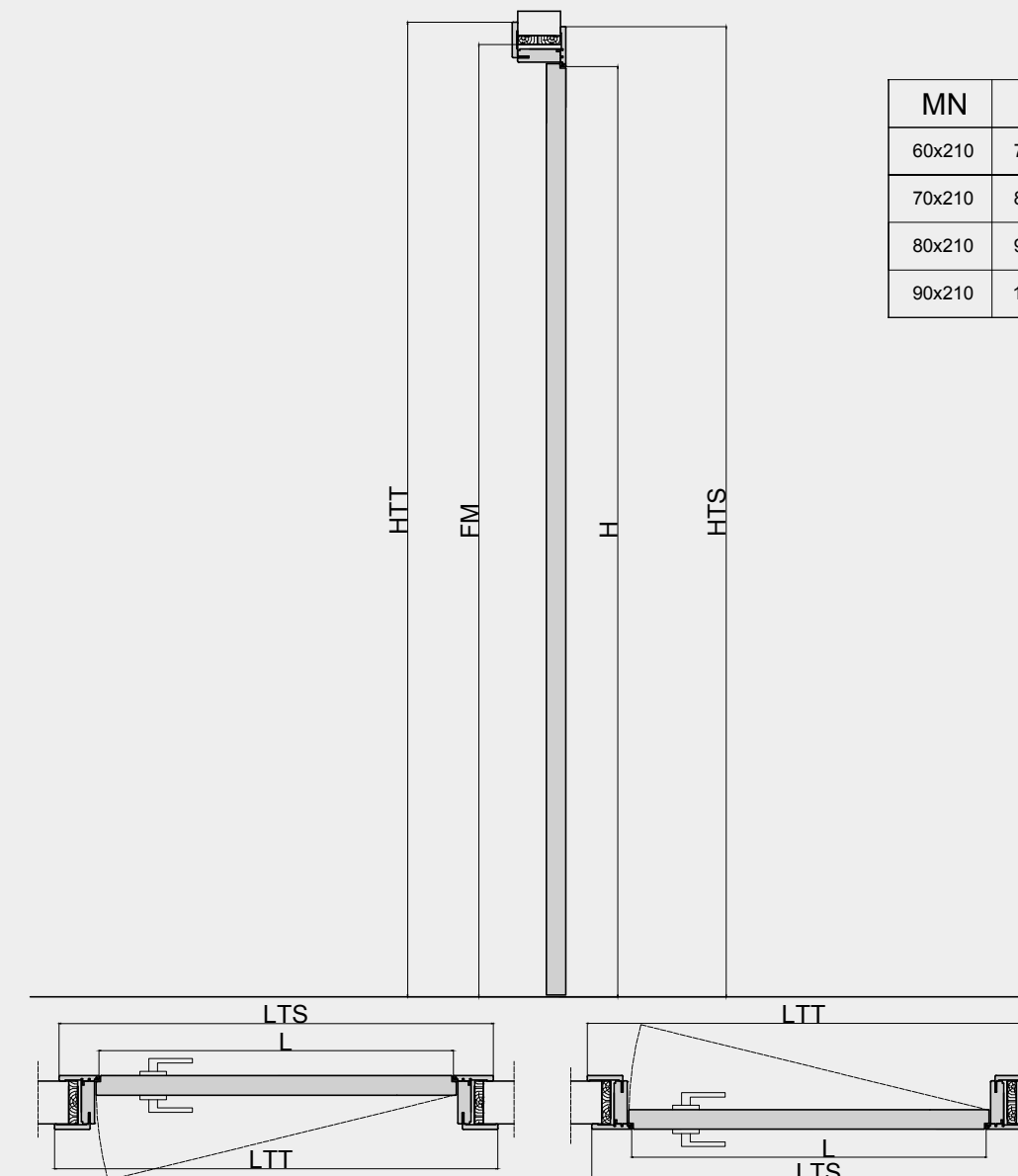

Caratteristiche tecniche Sistema B-UNO (collezione Kuadra, Soft, Incontri, Essenzia)

Technical sheet B-UNO system (Kuadra, Soft, Incontri and Essenzia collection)

Caractéristiques techniques système B-UNO (collecion Kuadra, Soft, Incontri et Essenzia)

Características técnicas sistema B-UNO (colección Kuadra, Soft, Incontri y Essenzia)



*DETTAGLIO DELL'ANTA BORDATA SU TRE LATI.
SEZIONE DEL TELAIO STANDARD DA 10.2 CM
PER MURO DA 9.5 A 11 CM*

*Detail of the door bordered on three sides.
Standard frame section of 10.2 cm
for walls from 9.5 to 11 cm*

*Détail de la porte bordée sur trois côtés.
Coupe du cadre standard de 10.2 cm
pour un mur de 9.5 à 11 cm*

*Detalle de la hoja bordada de tres lados.
Sección estandar del marco de 10.2 cm
para pared de 9.5 a 11 cm*

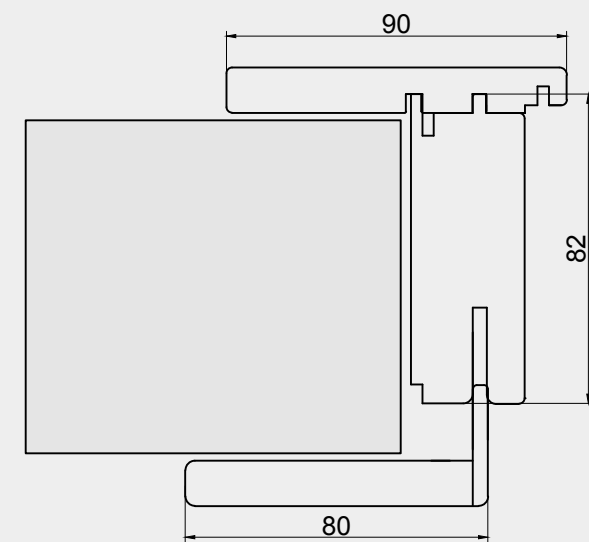

Per muro spesso da 7.5 a 9 cm
*For thickness from 7.5 to 9 cm
Elargissement pour epaisseur de mur de 7.5 à 9 cm
Expansión pared de 7.5 a 9 cm*

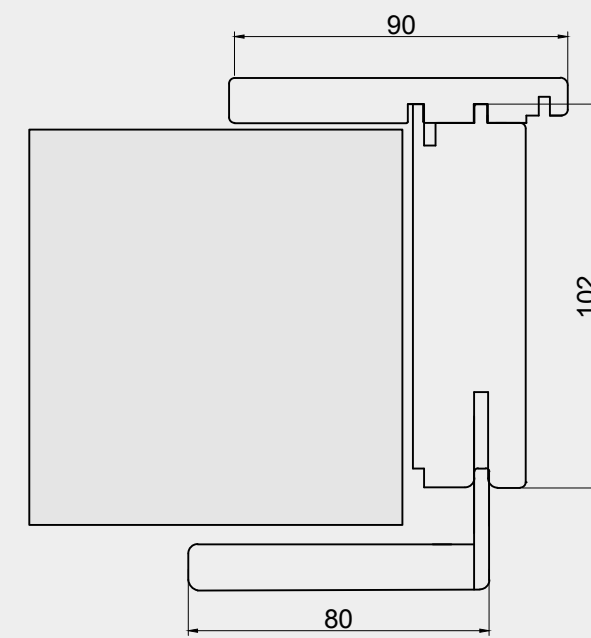

Per muro spesso da 9.5 a 11 cm
*For thickness from 9.5 to 11 cm
Elargissement pour epaisseur de mur de 9.5 à 11cm
Expansión pared de 9.5 a 11 cm*

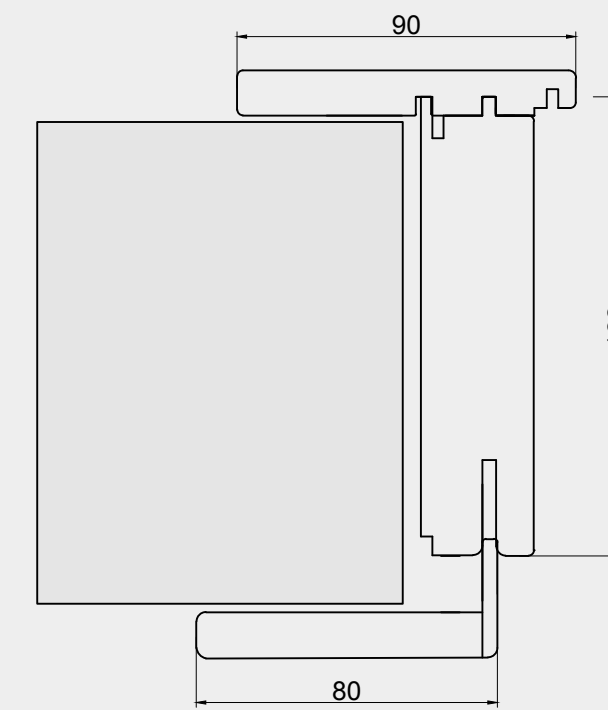

Per muro spesso da 11.5 a 13 cm
*For thickness from 11.5 to 13 cm
Elargissement pour epaisseur de mur de 11.5 à 13 cm
Expansión pared de 11.5 a 13 cm*

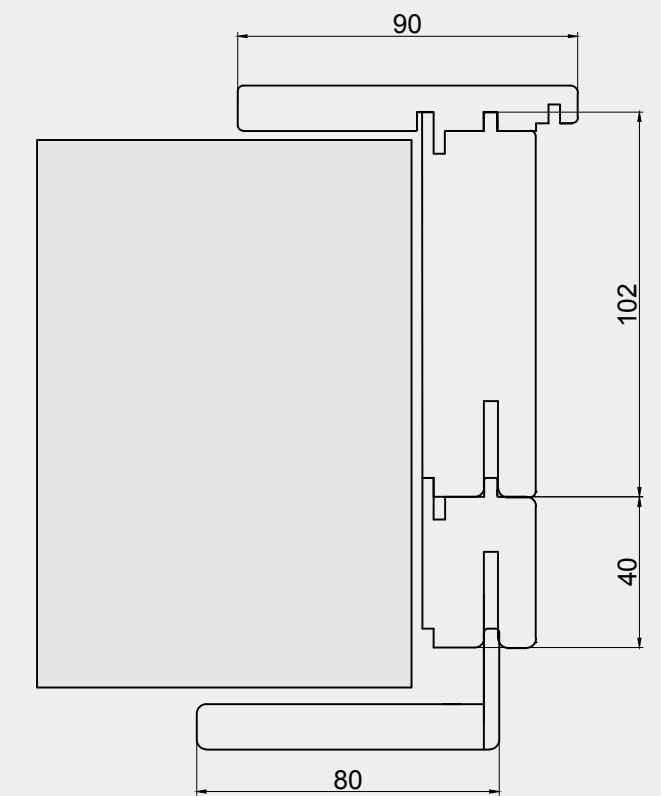

Allargamento per muro spesso da 13.5 a 15 cm
*Footing for thickness from 13.5 to 15 cm
Elargissement pour epaisseur de mur de 13.5 à 15 cm
Expansión pared de 13.5 a 15 cm*

Caratteristiche tecniche Sistema B-UNO (collezione Kuadra, Soft, Incontri, Essenzia)

Technical sheet B-UNO system (Kuadra, Soft ,Incontri and Essenzia collection)

Caractéristiques techniques système B-UNO (colletion Kuadra, Soft , Incontri et Essenzia)

Características técnicas sistema B-UNO (colección Kuadra, Soft, Incontri y Essenzia)

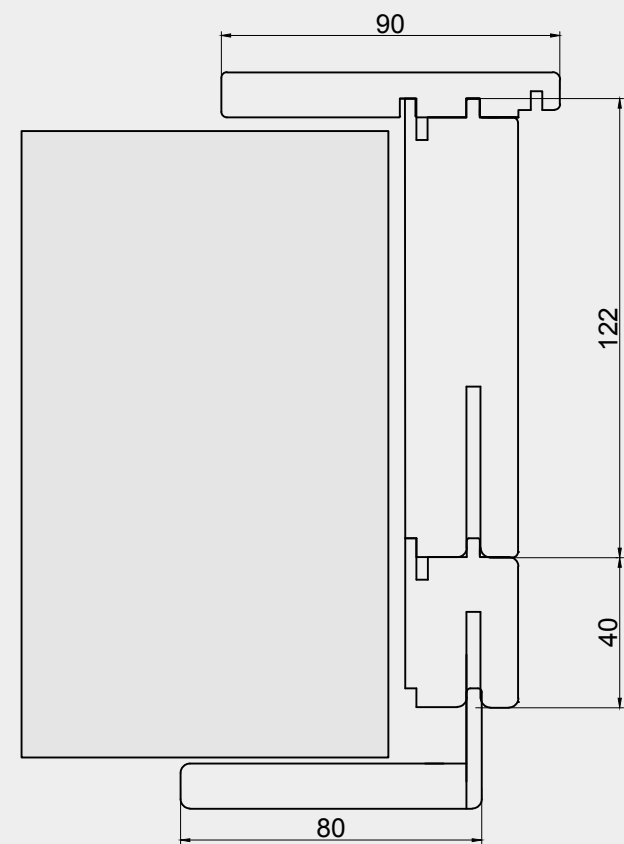

Allargamento per muro spesso da 15.5 a 17 cm
Footing for thickness from 15.5 to 17 cm
Elargissement pour epaisseur de mur de 15.5 à 17 cm
Expansión pared de 15.5 a 17 cm

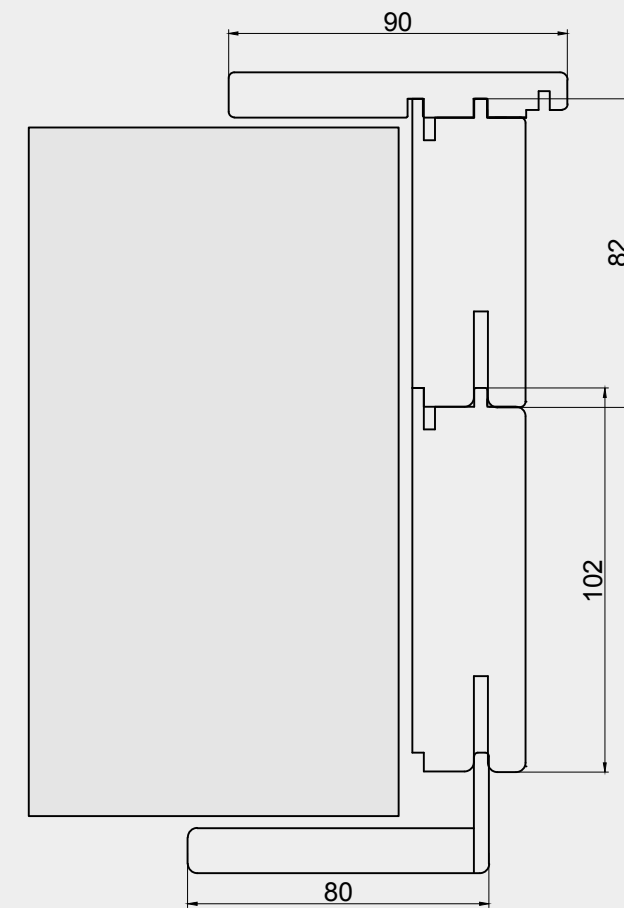

Allargamento per muro spesso da 17.5 a 19 cm
Footing for thickness from 17.5 to 19 cm
Elargissement pour epaisseur de mur de 17.5 à 19cm
Expansión pared de 17.5 a 19 cm

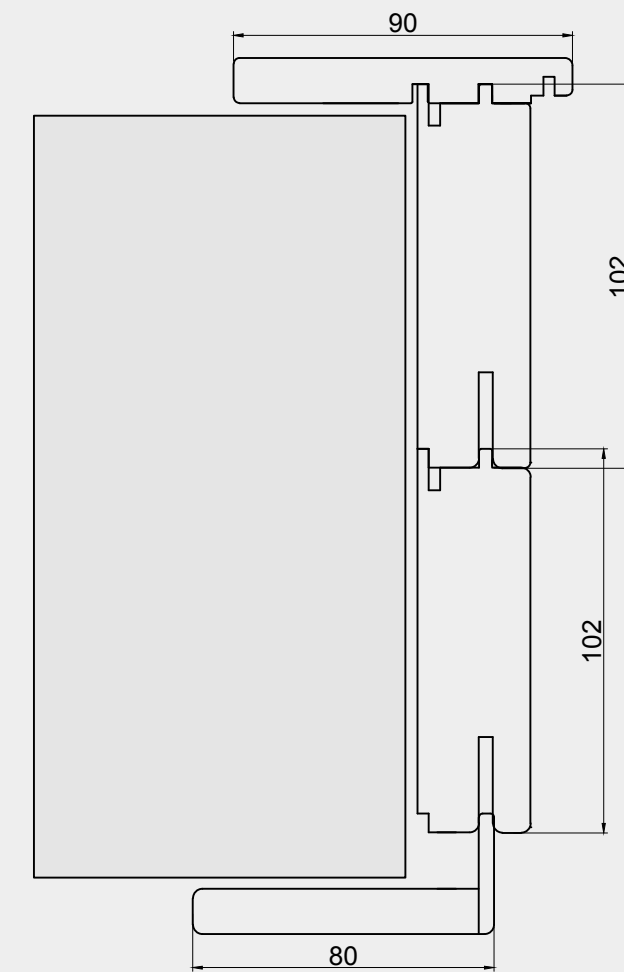

Allargamento per muro spesso da 19.5 a 21 cm
Footing for thickness from 19.5 to 21 cm
Elargissement pour epaisseur de mur de 19.5 à 21 cm
Expansión pared de 19.5 a 21 cm

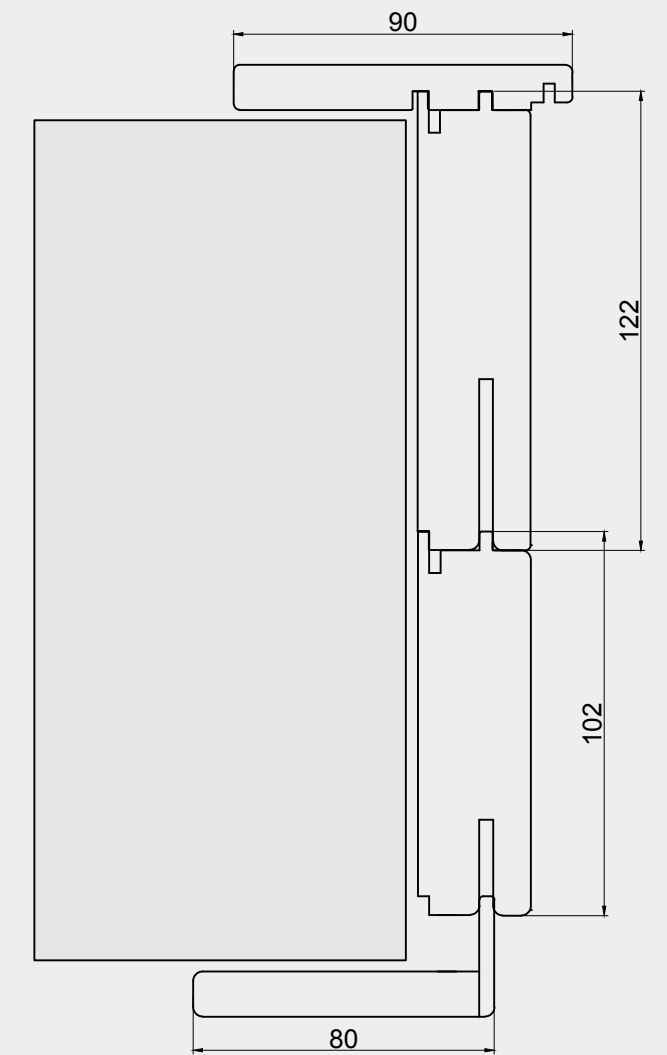

Allargamento per muro spesso da 21.5 a 23 cm
Footing for thickness from 21.5 to 23 cm
Elargissement pour epaisseur de mur de 21.5 à 23 cm
Expansión pared de 21.5 a 23 cm

Caratteristiche tecniche Sistema B-DUE (collezione Kuadra, Soft, Incontri, Essenzia)

Technical sheet B-DUE system (Kuadra, Soft, Incontri and Essenzia collection)

Caractéristiques techniques système B-DUE (collecion Kuadra, Soft, Incontri et Essenzia)

Características técnicas sistema B-DUE (colección Kuadra, Soft, Incontri y Essenzia)

1. 3 CERNIERE A SCOMPARSA
2. SERRATURA MAGNETICA
3. COMPLANARE NEL LATO A TIRARE
4. SPESSORE ANTA 44 MM
5. BORDATURA SU 3 LATI

1. 3 hidden hinges
2. Magnetic lock
3. Complanar in the side to pull
4. Thickness of the door 44 mm
5. Edge banding on 3 sides

1. 3 charnières dissimulées
2. Serrure magnétique
3. Partie affleurante du côté a
4. Tirer épaisseur de la porte 44 mm
5. Bordures sur 3 côtés

1. 3 bisagras ocultas
2. Cerradura magnética
3. Enrasada con la pared (lado a tirar)
4. Espesor hoja 44 mm
5. Borde de 3 lados

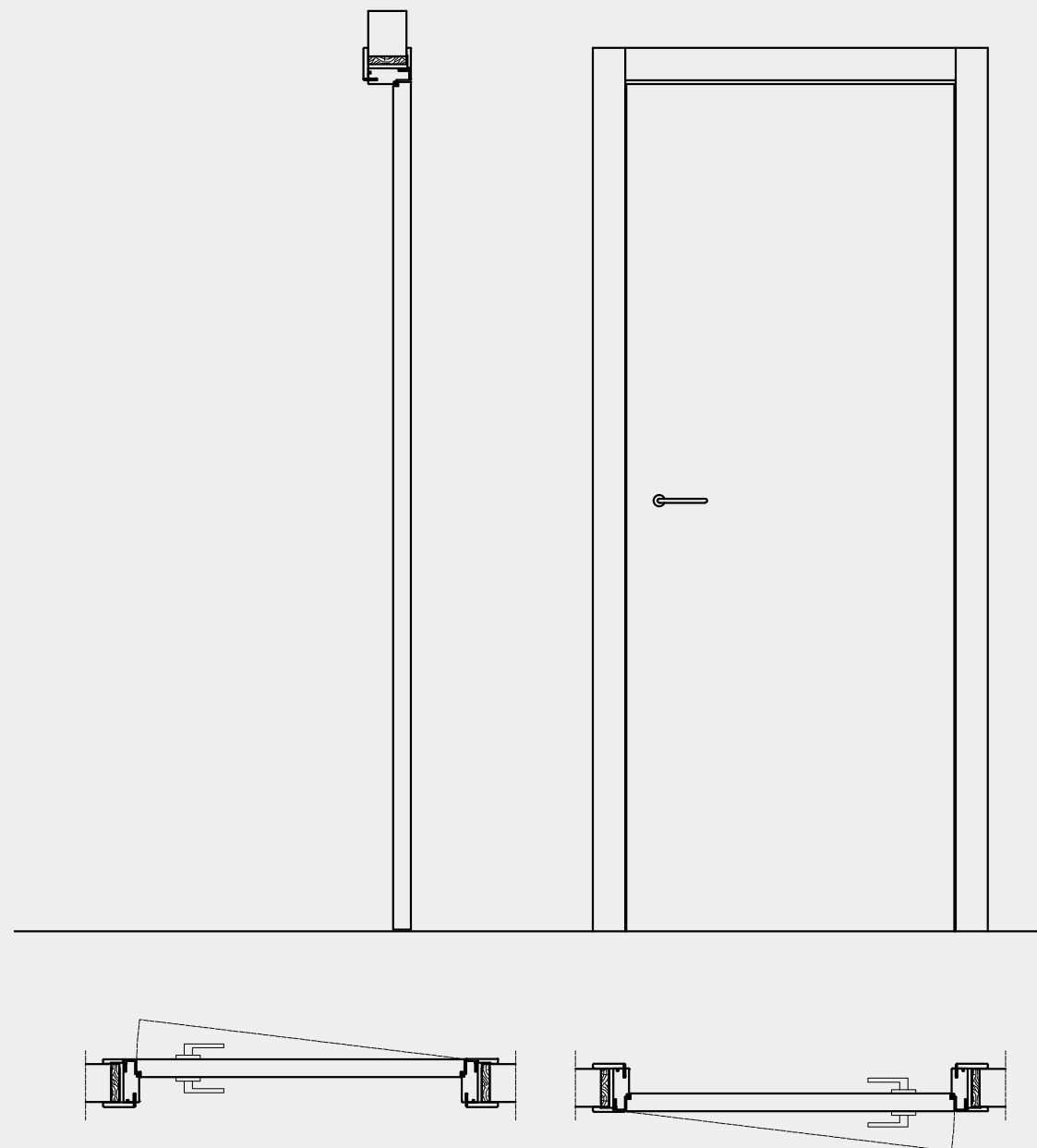

Misure ingombri per porta battente Sistema B-DUE (collezione Kuadra, Soft, Incontri, Essenzia)

*Overall dimensions for leaf door B-DUE system
(Kuadra, Soft, Incontri and Essenzia collection)*

*Dimensions hors tout pour porte battante système B-DUE
(collecion Kuadra, Soft, Incontri et Essenzia)*

*Medidas para la puerta batiente sistema B-DUE
(colección Kuadra, Soft, Incontri y Essenzia)*

MN	FM	L	LTS	LTT	H	HTS	HTT
60x210	70x215	60	78	78	210	219	219
70x210	80x215	70	88	88	210	219	219
80x210	90x215	80	98	98	210	219	219
90x210	100x215	90	108	108	210	219	219

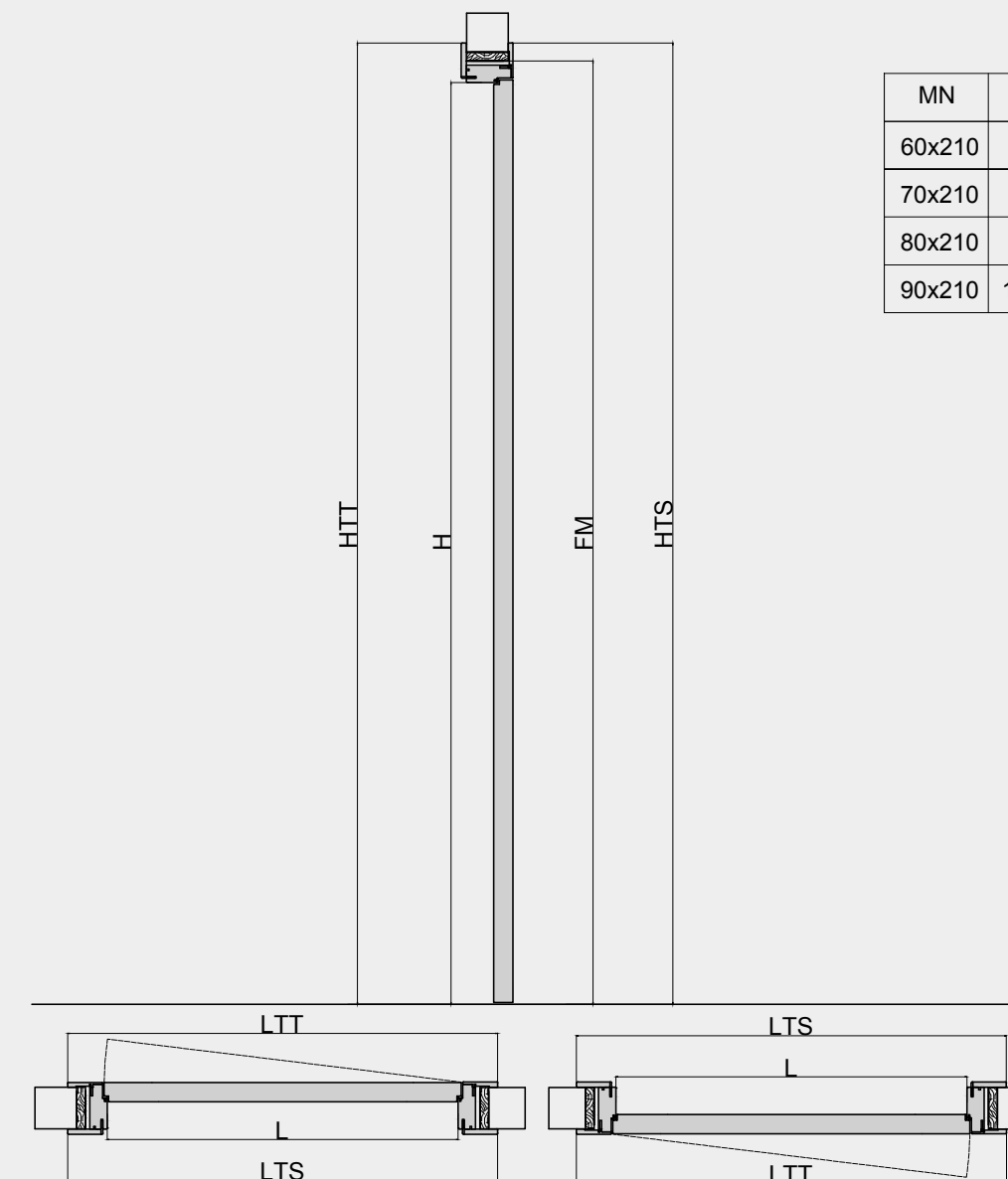

Caratteristiche tecniche Sistema B-DUE (collezione Kuadra, Soft, Incontri, Essenzia)

Technical sheet B-DUE system (Kuadra, Soft, Incontri and Essenzia collection)

Caractéristiques techniques système B-DUE (collecion Kuadra, Soft, Incontri et Essenzia)

Características técnicas sistema B-DUE (colección Kuadra, Soft, Incontri y Essenzia)



*DETTAGLIO DELL'ANTA BORDATA SU TRE LATI.
SEZIONE DEL TELAIO STANDARD DA 10.2 CM
PER MURO DA 9.5 A 11 CM*

*Detail of the door bordered on three sides.
Standard frame section of 10.2 cm
for walls from 9.5 to 11 cm*

*Détail de la porte bordée sur trois côtés.
Coupe du cadre standard de 10.2 cm
pour un mur de 9.5 à 11 cm*

*Detalle de la hoja bordada de tres lados.
Sección estandar del marco de 10.2 cm
para pared de 9.5 a 11 cm*

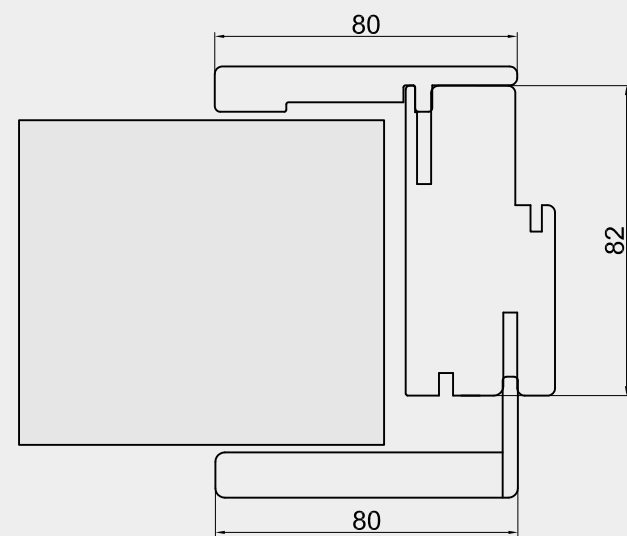

Per muro spesso da 7.5 a 9 cm

For thickness from 7.5 to 9 cm

Elargissement pour epaisseur de mur de 7.5 à 9 cm

Expansión pared de 7.5 a 9 cm

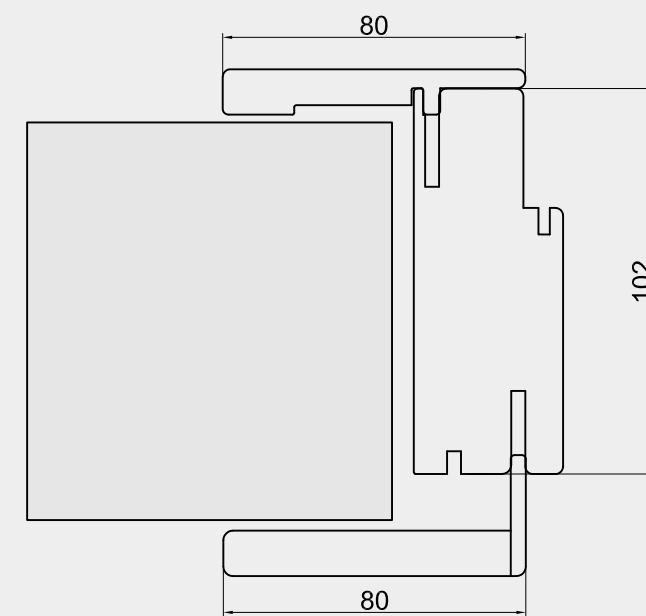

Per muro spesso da 9.5 a 11 cm

For thickness from 9.5 to 11 cm

Elargissement pour epaisseur de mur de 9.5 à 11 cm

Expansión pared de 9.5 a 11 cm

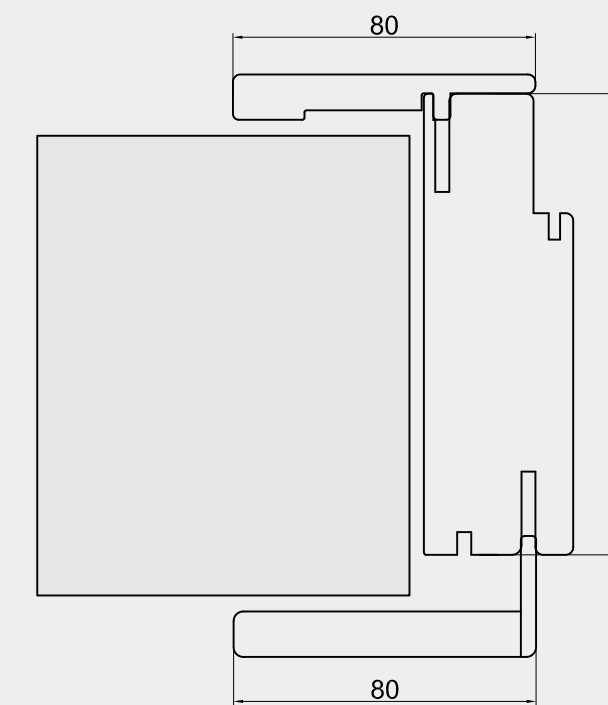

Per muro spesso da 11.5 a 13 cm

For thickness from 11.5 to 13 cm

Elargissement pour epaisseur de mur de 11.5 à 13 cm

Expansión pared de 11.5 a 13 cm

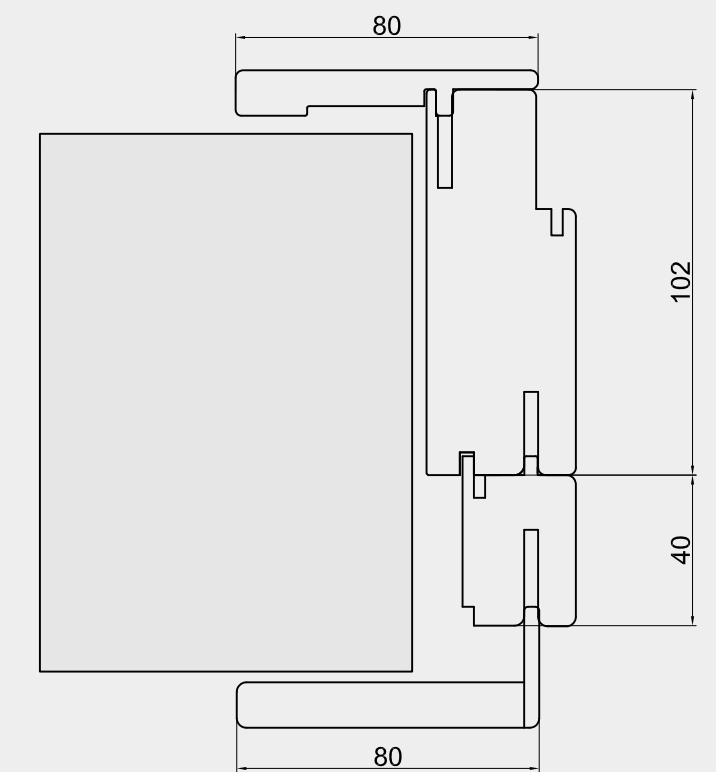

Allargamento per muro spesso da 13.5 a 15 cm

Footing for thickness from 13.5 to 15 cm

Elargissement pour epaisseur de mur de 13.5 à 15 cm

Expansión pared de 13.5 a 15 cm

Caratteristiche tecniche Sistema B-DUE (collezione Kuadra, Soft, Incontri, Essenzia)

Technical sheet B-DUE system (Kuadra, Soft, Incontri and Essenzia collection)

Caractéristiques techniques système B-DUE (colletion Kuadra, Soft, Incontri et Essenzia)

Características técnicas sistema B-DUE (colección Kuadra, Soft, Incontri y Essenzia)

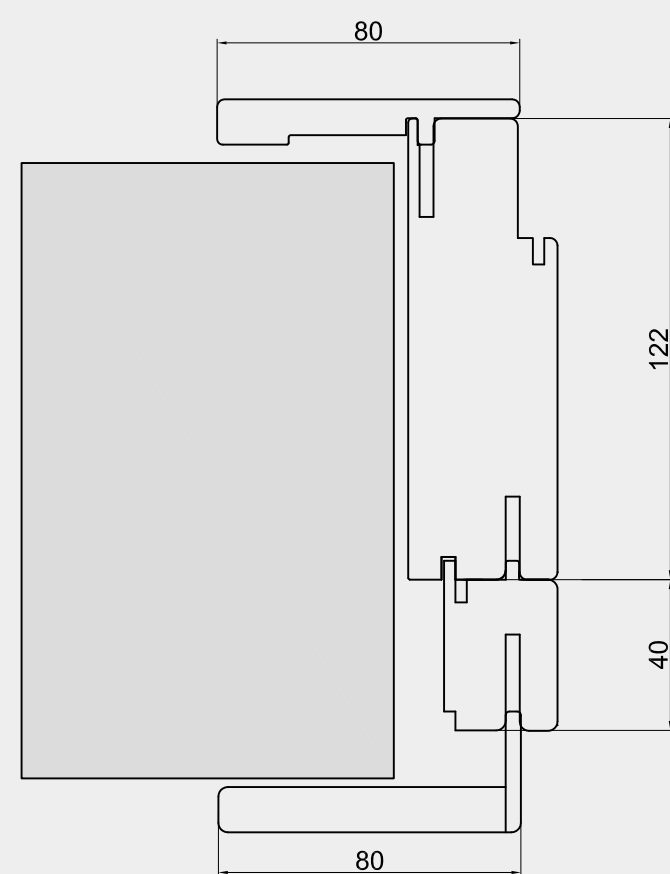

Allargamento per muro spesso da 15.5 a 17 cm

Footing for thickness from 15.5 to 17 cm

Elargissement elargissement pour epaisseur de mur de 15.5 à 17 cm

Expansión pared de 15.5 a 17 cm

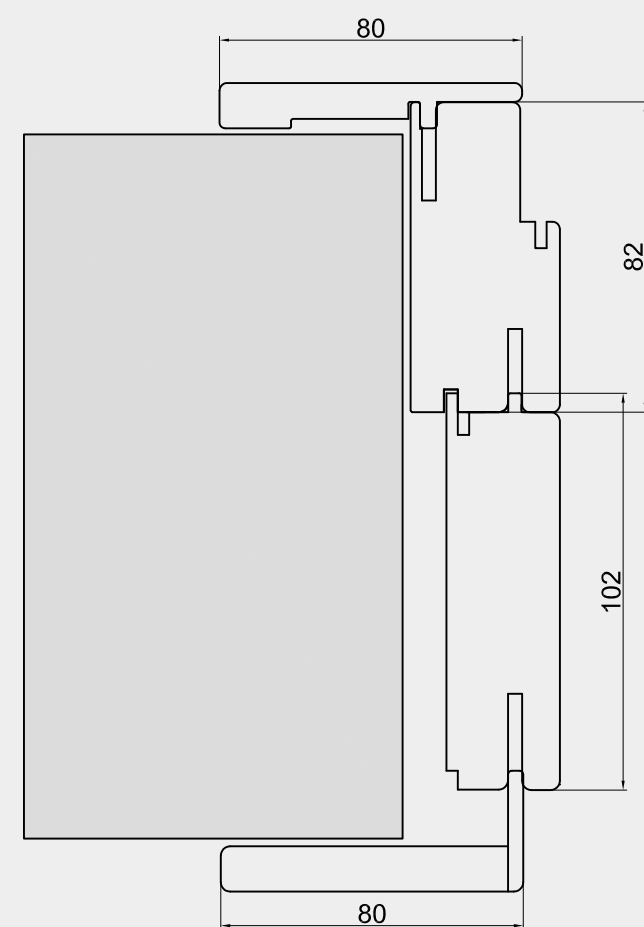

Allargamento per muro spesso da 17.5 a 19 cm

Footing for thickness from 17.5 to 19 cm

Elargissement pour epaisseur de mur de 17.5 à 19 cm

Expansión pared de 17.5 a 19 cm

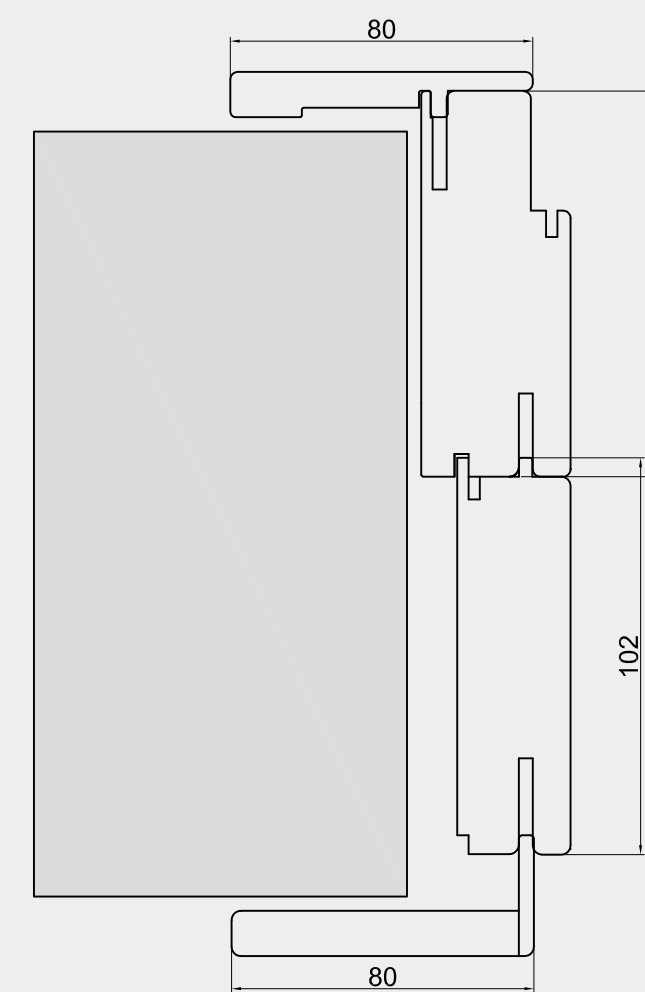

Allargamento per muro spesso da 19.5 a 21 cm

Footing for thickness from 19.5 to 21 cm

Elargissement pour epaisseur de mur de 19.5 à 21 cm

Expansión pared de 19.5 a 21 cm

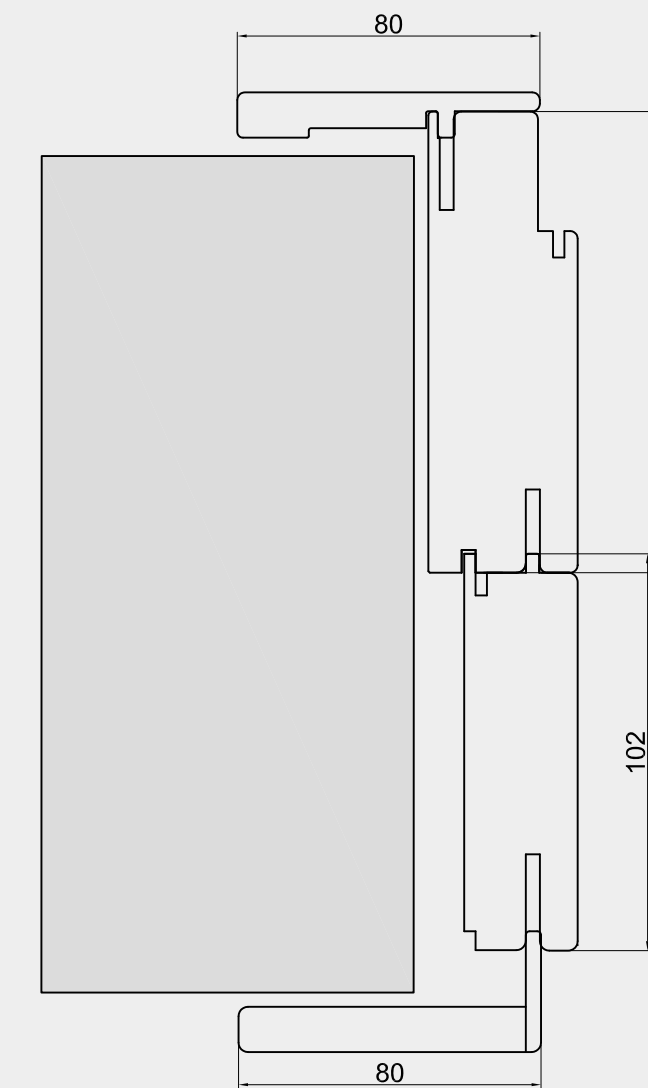

Allargamento per muro spesso da 21.5 a 23 cm

Footing for thickness from 21.5 to 23 cm

Elargissement pour epaisseur de mur de 21.5 à 23 cm

Expansión pared de 21.5 a 23 cm

Caratteristiche tecniche Sistema KO-ZERO (collezione Kuadra, Soft, Incontri, Essenzia)

Technical sheet KO-ZERO system (Kuadra, Soft, Incontri and Essenzia collection)
Caractéristiques techniques système KO-ZERO (colletion Kuadra, Soft, Incontri et Essenzia)
Características técnicas sistema KO-ZERO (colección Kuadra, Soft, Incontri y Essenzia)



PARTICOLARE DEL TELAIO IN ALLUMINIO

Aluminum frame detail
Détail du cadre en aluminium
Detalle marco de aluminio

- 1. TELAIO IN ALLUMINIO ESTRUSO SOVRA VERNICIABILE
- 2. SPESSORE ANTA 44 MM

1. Aluminum extruded frame, on paint
2. Thickness of the door 44 mm

1. Cadre en aluminium extrudé, sur peinture
2. Épaisseur de la porte 44 mm

1. Marco de aluminio extruido barnizable
2. Espesor hoja 44 mm

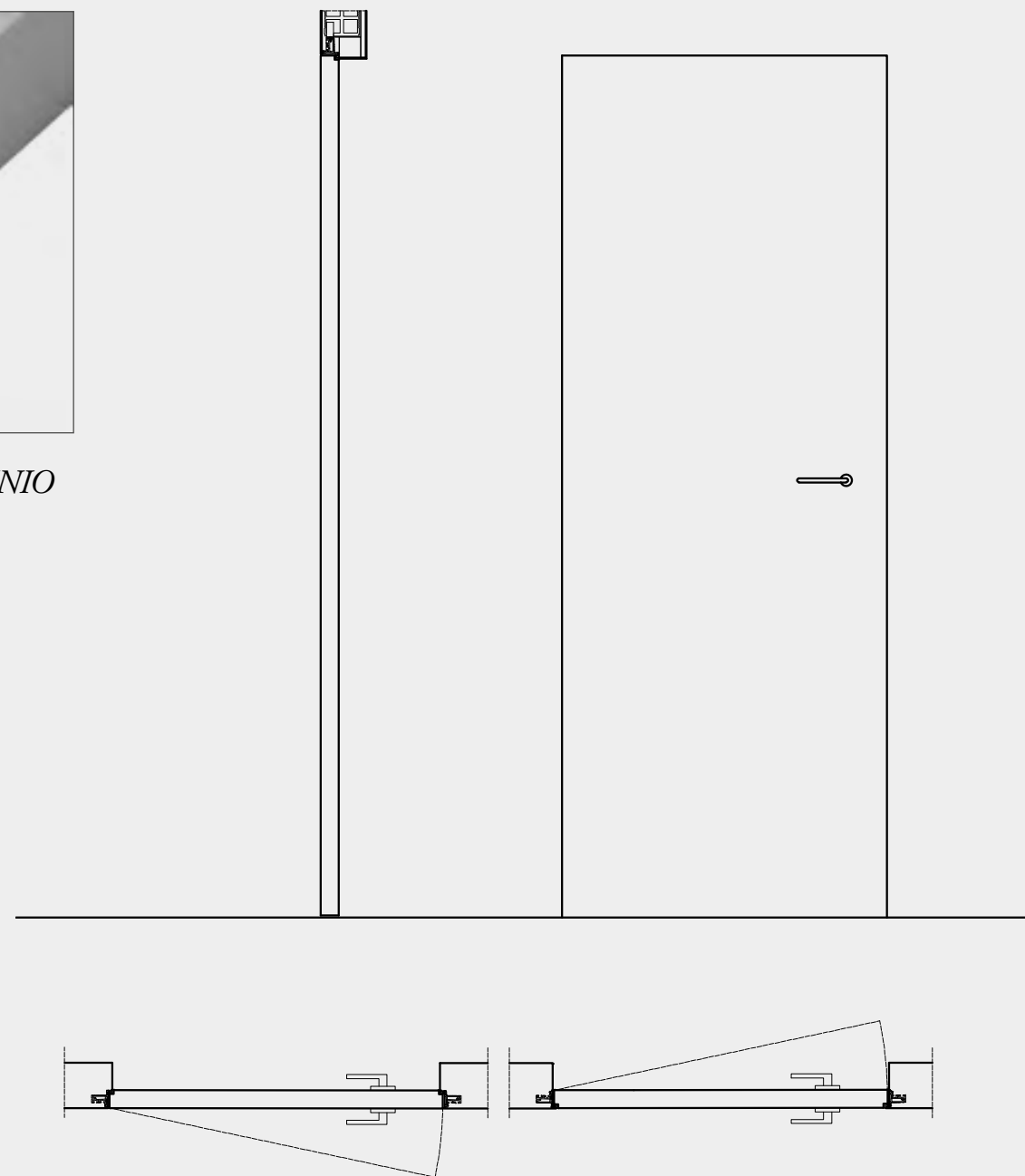

Misure ingombri per porta battente Sistema KO-ZERO (collezione Kuadra, Soft, Incontri, Essenzia)

Overall dimensions for leaf door KO-ZERO system (Kuadra, Soft, Incontri and Essenzia collection)
Dimensions hors tout pour porte battante système KO-ZERO (colletion Kuadra, Soft, Incontri et Essenzia)
Medidas para la puerta batiente sistema KO-ZERO (colección Kuadra, Soft, Incontri y Essenzia)

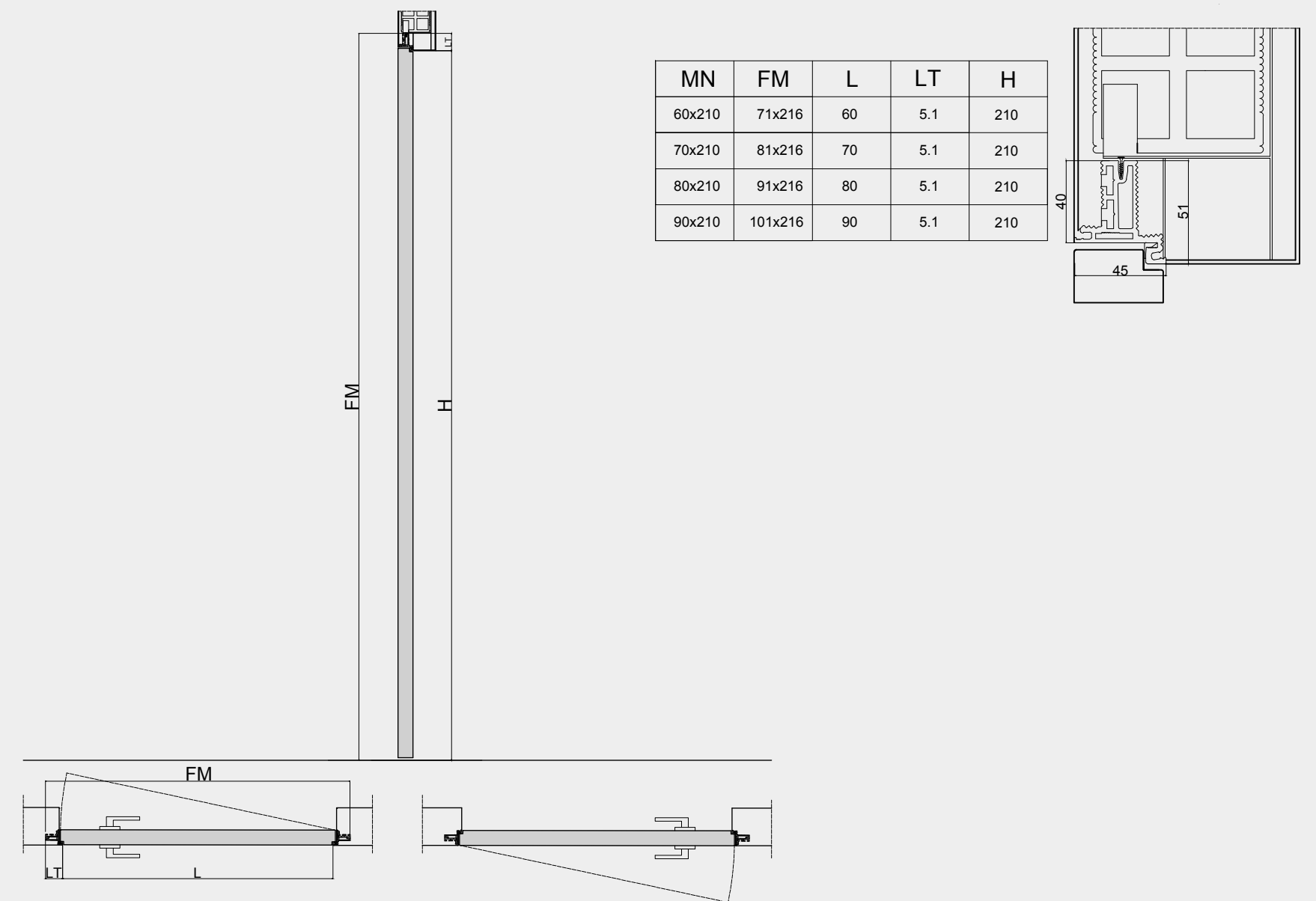

L'EVOLUZIONE DELLE TECNOLOGIE E LA CONTINUA RICERCA PORTANO ITALPORTE AD UN CONTINUO MIGLIORAMENTO DEI SUOI PRODOTTI: LE EVENTUALI MODIFICHE APPORTATE, RISPETTO AL PRESENTE CATALOGO, SONO ESCLUSIVAMENTE INDIRIZZATE A RAGGIUNGERE TALE OBIETTIVO. QUESTI MIGLIORAMENTI POTRANNO ESSERE REALIZZATI SENZA ALCUN PREAVVISO. LE IMMAGINI RIPORTATE NON DEVONO ESSERE CONSIDERATE VINCOLANTI AI FINI DELLA FORNITURA DELLE PORTE. QUESTO CATALOGO NON È UN DOCUMENTO CONTRATTUALE. LA RIPRODUZIONE, ANCHE PARZIALE DI GRAFICA, IMMAGINI E TESTI È VIETATA. LA RIPRODUZIONE DELLE IMMAGINI È CONCESSA SOLO SU AUTORIZZAZIONE SCRITTA DI ITALPORTE E SOLO CITANDO LA FONTE.

Italporte continues to improve its products thanks to evolving technology and continuous research: any changes to our existing range are made with this objective in mind. These changes may occur without prior notice. The actual doors should not be compared precisely to the images in this catalogue. This catalogue is not a contractual document. Reproduction of the layout, images or text is prohibited. Reproduction of the images is permitted only with written authorisation from Italporte and with acknowledgement of the source.

L'évolution des technologies et la recherche continue conduisent à une amélioration continue de ses produits: toute modification apportée par rapport à ce catalogue vise exclusivement à atteindre cet objectif. Ces améliorations peuvent être apportées sans préavis. Les images présentées ne doivent pas être considérées comme contraignantes dans le but de fournir les portes. Ce catalogue n'est pas un document contractuel. La reproduction même partielle de graphiques, d'images et de textes est interdite. La reproduction des images n'est accordée que sur autorisation écrite de Italporte et uniquement en citant la source.

La evolución de las tecnologías y la constante investigación traen Italporte a una mejora continua de sus productos: cualquier modificación realizada, con respecto a este catálogo, está orientada exclusivamente a alcanzar este objetivo. Estas mejoras pueden realizarse sin previo aviso. Las imágenes mostradas no deben ser consideradas vinculantes con el propósito de producir las puertas. Este catálogo no es un documento contractual. La reproducción, incluso parcial de gráficos, imágenes y textos está prohibida. La reproducción de las imágenes se concede solamente con un permiso escrito de Italporte y citando la fuente.

ntalpa